

For Professionals... Since 1857®

Utility Catalog

Edition 2



KLEIN TOOLS®

www.kleintools.com

Product Index

Company History . . . Page 1



Cable & Bolt Cutters Pages 2-6



Klein Pliers Pages 7-8



Wrenches Pages 9-12



Screwdrivers Page 13



Hammers Page 14



Knives & Cutting Tools Pages 15-18



Measuring Tools Page 19



Personal Protection Equipment Page 19



Lineman Buckets & Accessories Pages 20-24



Tool Bags Pages 25-27



Tool Pouches & Holders Pages 28-29



Lineman's Climbing Equipment Pages 30-37



Pole & Tree Climbers Pages 38-40



Block & Tackle Pages 41-44



Test & Measurement Pages 45-48

Warranty Page 49

Company History

Klein Tools was founded in 1857 by an industrious German immigrant, Mathias Klein, who began in the hand tool business when a broken side-cutting pliers was brought to his forge shop by a telegraph lineman. Mathias repaired the pliers by forging and finishing a new half for the tool and riveting it to the old half. Soon the lineman returned because the other original half of the pliers had broken and needed replacement. Mathias forged and finished the second half of the pliers and riveted it to the other replacement half – creating the first complete Klein pliers.

To this day, Klein Tools is proudly owned and managed by the Klein family. Over 150 years of hard work and dedication has earned Klein the reputation of supplying only the finest quality products for users of professional hand tools and occupational protective equipment.



Klein's reputation as a leading producer of professional-quality products is global. Klein Tools products are available worldwide through a well-established network of agents and distributors who stock what is needed for their particular markets.



Lineman's Tools

Klein Tools has established a reputation for manufacturing high quality tools to help linemen do their jobs. The company remains dedicated to making the best hand tools in the industry, and supporting linemen around the world with quality and reliability they can count on every day.



Lineman's Tools



Cable Cutters

Wire Rope Cutter

- Shear type blades for square, clean cuts.
- All forged construction; USA Steel.
- Non-slip vinyl grips.
- Hinge bolt with pin-set nut for proper blade tension.
- Cuts wire up to 9/32" (7 mm) and Stoffel® container seals.



63035SC

Cat. No.	Overall Length	Cuts	Maximum Cutting Capacity	Handle Color	Weight (lbs.)
63035SC	18" (457 mm)	Stoffel® Seals	9/32" (7 mm) wire rope and cables	red	2.00

Standard Cable Cutters

- Lightweight, yet efficient shear-type cable cutters.
- Replaceable hook-jaw blades grab and hold cable while shear-cutting action makes clean cuts.
- Exceptionally strong fiberglass handles with heavy vinyl grips for comfort and slip resistance.
- Heavy-duty pins in head serve as blade-stops.
- Jaws are forged tool steel with black-oxide finish for long life.
- Makes a clean, even cut for ease in fitting lugs and terminals.
- Beveled tips assure positive mating, and hinge on a rugged bolt with a pin-set nut to maintain proper blade tension.
- Communications Cable Cutter (Cat. No. 63047) cuts lead or rubber-covered communications cable.
- Not designed for cutting steel or ACSR.



63041

Cat. No.	Overall Length	Soft Cable-Cutting Maximum Capacity	MCM Cable-Cutting Maximum Capacity	Weight (lbs.)
63041	25-1/2" (648 mm)	1-3/8" (35 mm) diameter	500 copper, 750 aluminum	5.25
63045	32" (813 mm)	1-3/4" (44 mm) diameter	1000 copper, 1200 aluminum	8.00
63047	37" (940 mm)	900-pair soft copper and aluminum	up to 2-1/4" (57 mm) diameter	8.55
Replacement Cable Cutter Heads		Fits Klein Cat. No.		
63081			63041	2.05
63090			63045	3.30
63110			63047	3.50



Ratcheting Cutter – Heavy-Duty For Steel & ACSR

- Ratchet-action design provides maximum leverage with minimum effort for heavy-duty use.
- Cuts steel and ACSR.
- Forged, heat-treated, shear-type blades, plus 24" (609 mm) long steel handles with heavy vinyl grips for comfort and slip-resistance.
- Blade-advance knob for fast rotation of the blade to engage the cable or other material being cut, plus a quick-release mechanism allows for removal of the cable or rod before completion of the cut, if desired.
- Not designed for cutting EHS Guy Strand or reinforcement rod.



63700

Cat. No.	Overall Length	Soft Cable-Cutting Maximum Capacity	Communications Cable-Cutting Maximum Capacity	Weight (lbs.)
63700	36" (914 mm)	2-1/4" (57 mm) diameter	1-1/4" (32 mm) dia. ACSR, ACAR 7/16" (11 mm) dia. common guy strand 5/8" (16 mm) dia. steel wire rope 1/2" (13 mm) dia. steel rod (C.R.S. SOFT) 750 MCM (1-3/8" dia.) (35 mm) copper or aluminum	14.00

All dimensions are in inches and (millimeters).

⚠WARNING: Do NOT use to cut steel or ACSR.

⚠WARNING: Always wear approved eye protection.

⚠WARNING: NOT insulated. Plastic-dipped or slip-on plastic handles are NOT intended for protection against electrical shock.



Cable Cutters

Ratcheting Cable Cutters

- High-leverage ratchet mechanism for single-handed cutting of copper and aluminum cables, leaving no burrs or sharp edges.
- Patented two-step ratchet mechanism requires fewer strokes per cut.
- Quick release lever opens blades easily in every cutting position. (Allows removal of the cable before completion of cut).
- Precision ratcheting mechanism holds cable tight and allows rapid, straight cuts with minimum effort.
- Hardened steel cutting blades for lasting strength and sharpness.
- Plastic covered handles with hand guards for comfort and firm grip.
- Locking lever keeps handles closed for easy transport; fits in a toolbox or bag.
- Compact 10-11/4" design allows for one-handed use of the ratcheting cutter mechanism, so other hand can position cable to ensure proper cut (Cat. No. 63601).
- One-year warranty.



63060

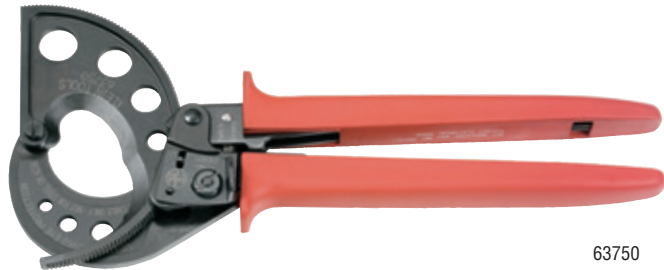

63750

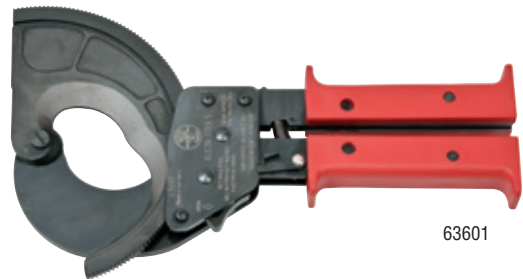

63601

⚠WARNING: Ratcheting Cable Cutters Cat. Nos. 63060, 63750 and 63601 do NOT use to cut steel or ACSR.

Cat. No.	MCM Maximum Cable Capacity		Communication Cable	ACSR	Overall Length	Handle Color	Weight (lbs.)
	Copper	Aluminum					
63060	400 MCM (185 mm ²)	600 MCM (300 mm ²)	1-1/8" (28 mm)	–	10-1/4" (260 mm)	red	1.32 lbs. (600 g)
63601	1000 MCM (500 mm ²)	1000 MCM (500 mm ²)	2-1/16" (52 mm)	–	10-1/4" (260 mm)	red	2.70 lbs. (1225 g)
63750	1000 MCM (500 mm ²)	1000 MCM (500 mm ²)	2-1/16" (52 mm)	–	12-1/8" (308 mm)	red	1.76 lbs. (800 g)
	Frequent Use: 750 MCM (400 mm ²)	Frequent Use: 750 MCM (400 mm ²)					

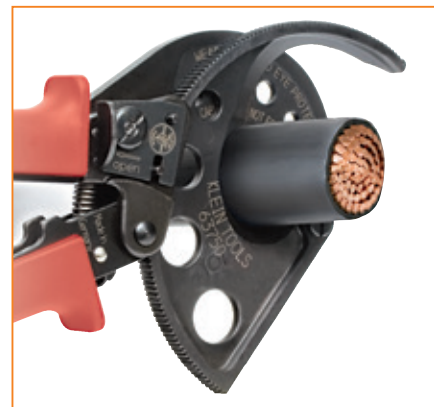

All dimensions are in inches and (millimeters).

⚠WARNING: Always wear approved eye protection.

⚠WARNING: NOT insulated. Plastic-dipped or slip-on plastic handles are NOT intended for protection against electrical shock.

Cable Cutters

ACSR Ratcheting Cable Cutters

- Tool can be locked when not in use.
- High leverage ratcheting mechanism for easier cutting (Cat. No. 63800ACSR).
- Plastic covered handles with hand guards for comfort and firm grip.
- NOT FOR EHS.

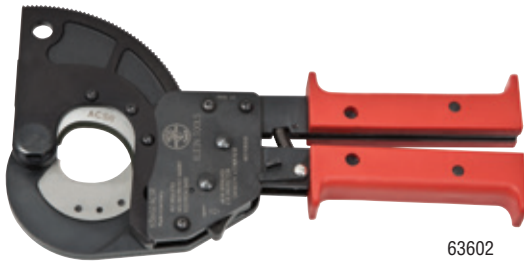

63602

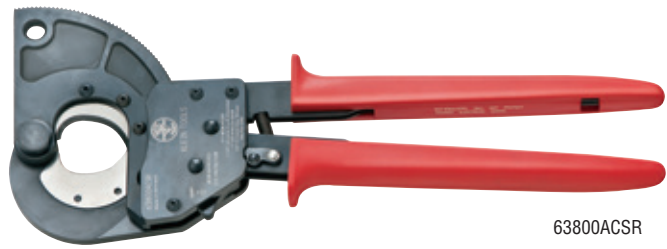

63800ACSR



63607

- Compact 10-1/4" design allows for one-handed use of the ratcheting cutter mechanism, so other hand can position cable to ensure proper cut (Cat. No. 63602).

Cat. No.	MCM Maximum Cable Capacity				Length	Handle Color	Weight (lbs.)
	ACSR	Stranded Aluminum & Copper	Solid Copper	Guy Strand			
63800ACSR	477 MCM (273 mm ²)	1-1/4" (32 mm)	1" (25 mm)	1/2" (13 mm)	13-3/4" (349 mm)	red	3.20 lbs. (1452 g)
63602	477 MCM (273 mm ²)	1-1/4" (32 mm)	1-1/4" (32 mm)	-	10-1/4" (260 mm)	red	3.20 lbs. (1452 g)
63607	336 MCM (170 mm ²)	600 MCM (300 mm ²)	400 MCM (185 mm ²)	-	10-1/4" (260 mm)	yellow	1.50 lbs. (680 g)
Replacement Cutting Inserts (with set of 6 screws)		Fits Klein Cat. No.					
63858	63800ACSR						

Drill-Operated ACSR Cable Cutter

- Chucks into a corded, cordless, or hydraulic drill for fast, clean cutting of large transmission cable.
- One-handed operation leaves the other hand free to position cable to ensure proper cut.
- Tough, worm-drive gears are built to last through typical conditions found during line work.
- Simply reverse drill to open cutting blades.
- Cuts up to 2156 MCM Bluebird ACSR cable and 1/2" (13 mm) Guy Strand (NOT FOR EHS).
- Compact, lightweight tool can be locked in closed position for pouch carrying or storage on truck.
- Side handle and torque arm included for use with drill - adds extra stability.

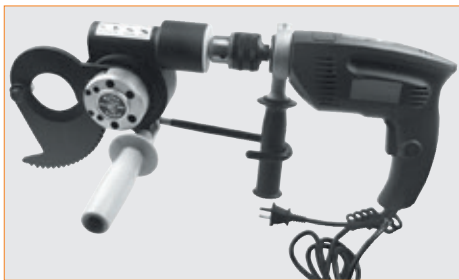

63805

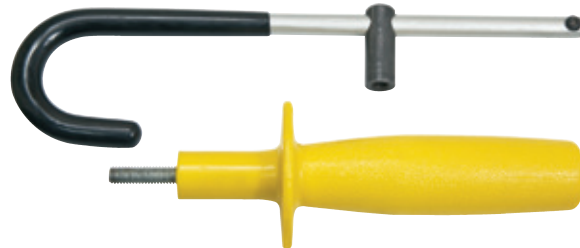

Cat. No.	MCM Maximum Cable Capacity				Guy Strand	Overall Length	Weight (lbs.)
	Copper	Aluminum	Communication Cable	ACSR & ACSS/TW			
63805	1.77" (45 mm)	1.77" (45 mm)	-	2156 MCM 1.76" (44.75 mm)	1/2" (13 mm) Utility Grade	12.6" (320 mm)	9.3 lbs.

All dimensions are in inches and (millimeters).

▲WARNING: Always wear approved eye protection.

▲WARNING: NOT insulated. Plastic-dipped or slip-on plastic handles are NOT intended for protection against electrical shock.



Cable Cutters

High-Leverage Cable Cutters

- Custom, US-made tool steel.
- Hot-riveted joint ensures smooth action and no handle wobble.
- Through-hardened (not case-hardened) for longer-lasting cutting surfaces.
- Beveled jaw tips provide proper mating and shearing action, which protects leading jaw edges.
- High-leverage design for exceptional cutting capability.
- Precision, one-hand shearing action.
- Cable-gripping shear-type jaws.
- Perfect for working in confined spaces.
- Can be carried in most tool pouches.



63050

▲WARNING: Do NOT use to cut steel or ACSR.

Cat. No.	Overall Length	Handle Color	Maximum Cable Cutting Capacity	Weight (lbs.)
63050	9-1/2" (241 mm)	red	4/0 aluminum, 2/0 soft copper, 100-pair 24 AWG communications cable	.90
Journeyman Series – Dual-material handles				
J63050	9-9/16" (243 mm)	red and black	4/0 aluminum, 2/0 soft copper, 100-pair 24 AWG communications cable	.98

Bolt Cutters

Bolt Cutters

- Handles have heavy vinyl grips with flat grip ends for 90° cuts.
- All-purpose, center-cut jaws for soft, medium, and hard metals.
- Forged, alloy tool steel jaws are precision ground for sure, efficient cutting and long life.
- Lockplate reinforcement prevents jaw bolts from loosening or turning, keeps jaws in correct alignment.
- One adjustment realigns cutting edges.
- 3-point toggle joint multiplies 50 lbs. of hand pressure on handles to 4,000 pounds at cutting jaws.



63124

Fiberglass Handles

Cat. No.	Handle Type	Overall Length	Soft & Medium Cutting Maximum Capacities*	Hard Material Cutting Maximum Capacities**	Handle Color	Weight (lbs.)
63118	fiberglass	18-1/4" (464 mm)	3/8" (10 mm)	1/4" (6 mm)	red	3.65
63124	fiberglass	24-1/2" (622 mm)	7/16" (11 mm)	5/16" (8 mm)	red	6.13
63130	fiberglass	30-1/2" (775 mm)	1/2" (13 mm)	3/8" (10 mm)	red	9.50
63136	fiberglass	36-1/2" (927 mm)	9/16" (14 mm)	7/16" (11 mm)	red	12.95

* Up to Brinell 300, Rockwell C31.

** Up to Brinell 400, Rockwell C42.

Replacement Fiberglass Handle Sets

Cat. No.	Fits Cat. No.	Weight (lbs.)
63119	63118	2.15
63131	63130	5.56
63137	63136	7.55



All dimensions are in inches and (millimeters).

▲WARNING: Always wear approved eye protection.

▲WARNING: NOT insulated. Plastic-dipped or slip-on plastic handles are NOT intended for protection against electrical shock.



Side-Cutting Pliers

Features:

Custom, US-made tool steel.

“Handform” handles for full gripping and cutting power.

Plastic-dipped handles[†] for comfort and ease of identification.

Unique handle tempering helps absorb the “snap” when cutting wire.

Hot-riveted joint ensures smooth action and no handle wobble.

Induction hardened cutting knives for long life.

Precision-hardened plier head for on-the-job toughness.

2000 SERIES[®] pliers available.

Cuts ACSR, screws, nails, and most hardened wire.

Sure-gripping cross-hatched knurled jaws.

[†] Journeyman pliers available. State-of-the-art, dual-material handles, which provide a better grip without sacrificing tool strength or durability.



High-Leverage Side-Cutting Pliers – Heavy-Duty Cutting 2000 SERIES[®]

Additional Features:

- Cuts ACSR, screws, nails and most hardened wire.
- High-leverage design. Rivet is closer to the cutting edge for 46% greater cutting and gripping power than other plier designs.
- Streamlined design with sure-gripping, cross-hatched knurled jaws.
- Features combination polished and black-oxide finish.



D2000-9NE

Cat. No.	Nose Type	Overall Length	Jaw Length	Jaw Width	Jaw Thickness	Knife Length	Handle Finish	Handle Color	Weight (lbs.)
D2000-7	New England	7-7/8" (200 mm)	1-9/32" (33 mm)	1-1/32" (26 mm)	1/2" (13 mm)	3/4" (19 mm)	plastic-dipped	royal blue	.66
D2000-8	New England	8-11/16" (221 mm)	1-7/16" (37 mm)	1-7/64" (28 mm)	5/8" (16 mm)	3/4" (19 mm)	plastic-dipped	royal blue	.85
D2000-9NE	New England	9-3/8" (238 mm)	1-19/32" (41 mm)	1-1/4" (32 mm)	5/8" (16 mm)	25/32" (20 mm)	plastic-dipped	royal blue	1.09
HD2000-9NE	New England	9-1/2" (241 mm)	1-19/32" (41 mm)	1-1/4" (32 mm)	5/8" (16 mm)	25/32" (20 mm)	heavy-duty, oversized, plastic-dipped	light red	1.15

Journeyman 2000 Series – Dual-material handles

J2000-9NE	New England	9-1/2" (241 mm)	1-19/32" (41 mm)	1-1/4" (32 mm)	5/8" (16 mm)	25/32" (20 mm)	Journeyman	light blue/black	1.13
-----------	-------------	-----------------	------------------	----------------	--------------	----------------	------------	------------------	------

Refer to the insulated section for insulated pliers.

High-Leverage Side-Cutting Pliers

Additional Features:

- High-leverage design. Rivet is closer to the cutting edge for 46% greater cutting and gripping power than other plier designs.
- Sure-gripping, cross-hatched knurled jaws.

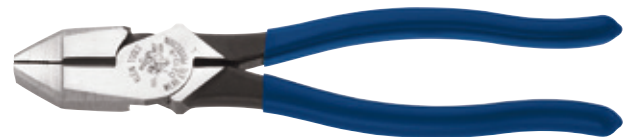

D213-9

Cat. No.	Nose Type	Overall Length	Jaw Length	Jaw Width	Jaw Thickness	Knife Length	Handle Finish	Handle Color	Weight (lbs.)
D213-9	Square	9-3/8" (238 mm)	1-19/32" (41 mm)	1-1/4" (32 mm)	5/8" (16 mm)	25/32" (20 mm)	plastic-dipped	dark blue	1.07

All dimensions are in inches and (millimeters).

▲WARNING: Always wear approved eye protection.

▲WARNING: NOT insulated. Plastic-dipped or slip-on plastic handles are NOT intended for protection against electrical shock.



Side-Cutting Pliers

High-Leverage Side-Cutting Pliers – Lineman’s Bolt-Thread Holding

Additional Features:

- Hinge opening holds and cleans 5/8" pole line and hardware bolts or threaded rods.
- High-leverage design. Rivet is closer to the cutting edge for 46% greater cutting and gripping power than other plier designs.
- Streamlined design with rounded nose and sure-gripping, cross-hatched knurled jaw.



D213-9NETH



Cat. No.	Nose Type	Overall Length	Jaw Length	Jaw Width	Jaw Thickness	Knife Length	Handle Finish	Handle Color	Weight (lbs.)
D213-9NETH	New England	9-3/8" (238 mm)	1-19/32" (41 mm)	1-1/4" (32 mm)	5/8" (16 mm)	25/32" (20 mm)	plastic-dipped	dark blue	1.18
HD213-9NETH	New England	9-1/2" (241 mm)	1-19/32" (41 mm)	1-1/4" (32 mm)	5/8" (16 mm)	25/32" (20 mm)	heavy-duty, oversized, plastic-dipped	light red	1.12

2000 Series* – Heavy-duty cutting knives

D2000-9NETH	New England	9-3/8" (238 mm)	1-19/32" (41 mm)	1-1/4" (32 mm)	5/8" (16 mm)	25/32" (20 mm)	plastic-dipped	royal blue	1.18
-------------	-------------	-----------------	------------------	----------------	--------------	----------------	----------------	------------	------

*Cuts ACSR, screws, nails, and most hardened wire. Features combination polished and black-oxide finish.

Pliers

Pump Pliers

Pump Pliers

- Secure tongue and groove design for non-slip grip – even with heavy pressure.
- Wide range of versatile jaw positions.



D502-10



J502-10

Cat. No.	Overall Length	Max. Jaw Capacity	Handle Finish	Handle Color	Weight (lbs.)
D502-6	6-1/2" (165 mm)	7/8" (22 mm)	plastic-dipped	yellow	.41
D502-10	10" (254 mm)	1-3/4" (45 mm)	plastic-dipped	yellow	.97
D502-12	12-1/4" (311 mm)	2-3/8" (60 mm)	plastic-dipped	yellow	1.37
D502-16	16-3/4" (425 mm)	4-1/4" (108 mm)	plastic-dipped	yellow	3.22

Journeyman Series – Dual-material handles

J502-10	10-1/4" (260 mm)	1-3/4" (45 mm)	Journeyman	yellow/black	1.02
---------	------------------	----------------	------------	--------------	------

All dimensions are in inches and (millimeters).

▲WARNING: Always wear approved eye protection.

▲WARNING: NOT insulated. Plastic-dipped or slip-on plastic handles are NOT intended for protection against electrical shock.



Adjustable Wrenches

Features:

Precision-machined jaws are individually chosen and assembled by hand for smooth operation.

Available in high-capacity.

Corrosion resistant.

Durable chrome-plated finish.

Knurl turns smoothly for easy operation.

Contoured handles for comfortable use.



Rail is ground for precision fit.

Heat-treated for long life.



Adjustable Wrenches – Standard Capacity

Additional Features:

- Forged heat-treated alloy steel for maximum strength and light weight.
- High polish chrome finish.



506-8

Cat. No.	Handle Type	Handle Finish	Length	Capacity	Weight (lbs.)
500-18	tapered	plain	18-1/4" (463 mm)	2-1/16" (52 mm)	4.67
500-24	tapered	plain	24" (610 mm)	2-1/2" (63 mm)	7.76

Socket Wrenches

3/8-Inch Drivers and Extensions

Cat. No.	Description	Weight (lbs.)
65720	7-1/2" ratchet	.73
65721	1-3/4" extension	.09
65722	3" extension	.15
65723	6" extension	.30
65724	5/8" spark plug socket	.21

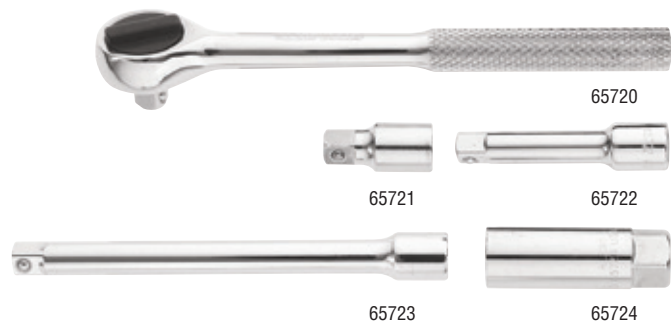

65720

65721

65722

65723

65724

All dimensions are in inches and (millimeters).

▲WARNING: Always wear approved eye protection.

▲WARNING: NOT insulated. Plastic-dipped or slip-on plastic handles are NOT intended for protection against electrical shock.

▲WARNING: Do NOT push or hammer wrench.

▲WARNING: Do NOT extend handle length.



Ratcheting Box Wrenches

Features:

Different size opening on each end.

Corrosion resistant.

Durable chrome-plated finish.

For use in confined spaces and on long studs.

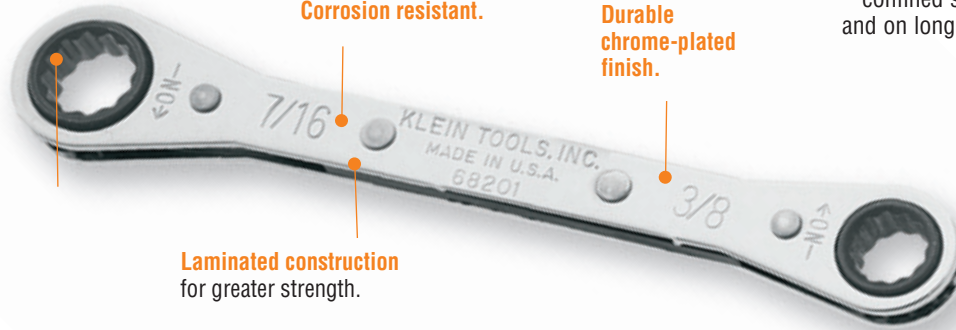

Laminated construction for greater strength.



Reverse ratcheting action by simply turning wrench over.

5-Piece Ratcheting Box Wrench Set

Additional Features:

- Five ratcheting box wrenches packed in a vinyl 8-1/2"W x 10"H (216 mm x 254 mm) roll-up pouch with individual pockets.
- Wrenches flip over to reverse ratchet.

Cat. No.	Set Contains	Weight (lbs.)	
68221		1.45	
Cat. No.	Point	Size	Length
68200	12	1/4" x 5/16"	4-3/8" (112 mm)
68201	12	3/8" x 7/16"	5-1/2" (140 mm)
68202	12	1/2" x 9/16"	6-7/8" (175 mm)
68203	12	5/8" x 11/16"	8-1/4" (216 mm)
68204	12	5/8" x 3/4"	8-1/4" (216 mm)



68221

7-Piece Ratcheting Box Wrench Set

Additional Feature:

- Set of the ratcheting box wrenches in vinyl roll-up pouch.

Cat. No.	Set Contains	Weight (lbs.)	
68222		2.65	
Cat. No.	Point	Size	Length
68200	12	1/4" x 5/16"	4-3/8" (112 mm)
68201	12	3/8" x 7/16"	5-1/2" (140 mm)
68202	12	1/2" x 9/16"	6-7/8" (175 mm)
68203	12	5/8" x 11/16"	8-1/4" (216 mm)
68204	12	5/8" x 3/4"	8-1/4" (216 mm)
68205	12	11/16" x 3/4"	9-1/4" (235 mm)
68206	12	13/16" x 7/8"	9-1/4" (235 mm)



68222

All dimensions are in inches and (millimeters).

▲WARNING: Always wear approved eye protection.

▲WARNING: Never use on or near live electrical circuits.

▲WARNING: Do NOT push or hammer wrench.

▲WARNING: Do NOT extend handle length.



Ratcheting Box Wrenches

Ratcheting Box Wrenches

Cat. No.	Point	Size	Length	Weight (lbs.)
68200	12	1/4" x 5/16"	4-3/8" (112 mm)	.13
68201	12	3/8" x 7/16"	5-1/2" (140 mm)	.18
68202	12	1/2" x 9/16"	6-7/8" (175 mm)	.29
68203	12	5/8" x 11/16"	8-1/4" (216 mm)	.43
68204	12	5/8" x 3/4"	8-1/4" (216 mm)	.42



68201

Cat. No.	Point	Size	Length	Weight (lbs.)
68205	12	11/16" x 3/4"	9-1/4" (235 mm)	.52
68206	12	13/16" x 7/8"	9-1/4" (235 mm)	.69

Ratcheting Offset Box Wrenches

3-Piece Fully Reversible Ratcheting Offset Box Wrench Set

- Set of three offset and fully reversible ratcheting box wrenches.
- Different size single-hex openings on each end.
- Includes heavy-duty vinyl pouch.

Cat. No.	Set Contains	Weight (lbs.)
68244		.61

Cat. No.	Point	Size	Length
68234	6	1/4" x 5/16"	4-3/8" (112 mm)
68236	6	3/8" x 7/16"	5-1/2" (140 mm)
68238	6	1/2" x 9/16"	6-3/4" (171 mm)



68244

5-Piece Fully Reversible Ratcheting Offset Box Wrench Set

- Set of the offset reversible ratchet box wrenches in vinyl roll-up pouch.
- Two grommet holes for hanging.

Cat. No.	Set Contains	Weight (lbs.)
68245		1.57

Cat. No.	Point	Size	Length
68234	6	1/4" x 5/16"	4-3/8" (112 mm)
68236	6	3/8" x 7/16"	5-1/2" (140 mm)
68238	6	1/2" x 9/16"	6-3/4" (171 mm)
68240	12	5/8" x 11/16"	8-1/8" (206 mm)
68242	12	3/4" x 7/8"	9-1/8" (232 mm)



68245

Specialty Wrenches

Can Wrench



68005

- Two tools in one; saves space in your pouch.
- One end opens telephone box fasteners, the other end tightens nuts on binding-post terminals.
- The 7/16" socket has a black finish and the 3/8" socket has a silver finish.
- Sockets are 1-1/4" (32 mm) deep to fit over long binding posts and are thin-walled for easy access into tight areas.
- Socket ends are color-coded for quick identification of socket sizes.
- Hex-socket design enables using a wrench to obtain extra torque.
- High-impact, break-resistant handle for long and dependable service.
- Sockets are heat-treated, alloy steel.

Cat. No.	Description	Length	Handle Diameter	Weight (lbs.)
68005	3/8" and 7/16" hex nut	7" (178 mm)	1" (25 mm)	.35

Bell System Type



3146B

- Similar to standard lineman's wrench, but with end openings sized to NEMA hardware specifications.
- Silver painted finish.

Cat. No.	Description	Length	Weight (lbs.)
3146B	Large end has 1-1/16" and 1-3/16" openings. Small end has 11/16" and 7/8" openings.	13" (330 mm)	1.76

See warnings on the previous page.



Lineman's Wrenches

Ratcheting Lineman's Wrenches

- Bolt-through design allows bolts to pass through the socket.
- 3/4" and 1" x 1-1/8" combination square socket for most common utility hardware.
- Bright yellow socket for easy visibility.
- Works on most common utility pole hardware, such as lag bolts, "C" clamps and suspension bolts.
- KT155T and KT155HD also offer two popular wrench sizes: 9/16" and 3/4".
- Heavy duty design (KT155HD).



KT151T



5-in-1

KT155HD



5-in-1

KT155T

Cat. No.	Description	Length	Weight (lbs.)
KT155HD	Ratcheting Lineman's Wrench - Heavy Duty	12" (305 mm)	2.10
KT151T	Ratcheting Lineman's Wrench	13" (330 mm)	2.12
KT155T	5-in-1 Lineman's Wrench	9-3/8" (238 mm)	1.42

Lineman's Box Wrenches

- Chrome plated finish resists corrosion.

Cat. No. KT223X4-INS

- "See-through" insulating handle confirms metal ends are not connected.
- 1/2", 9/16", 5/8" and 3/4" sizes in one tool; 12-point sockets.
- Reverse ratcheting action by reversing switches on each end of the wrench.
- Textured grooves in handle prevent slipping.
- Solid, one piece design (Cat. No. KT203).



KT223X4-INS



KT203

Cat. No.	Description	Socket Size	Length	Weight (lbs.)
KT223X4-INS	Insulating Lineman's Box Wrench	1/2", 9/16", 5/8" & 3/4"	9" (229 mm)	.70
KT203	Lineman's Box Wrench	9/16" x 3/4"	8-1/8" (206 mm)	.55

Lineman's Wrenches



3146

- Forged from special bar steel and heat-treated for long life.
- Each end has two different size openings.
- Hole is provided at larger end for turning-in standard pole steps.
- Wrench is suited for use on heavy three-bolt guy clamps on which clearance is limited.
- Dark blue painted finish (small end is painted silver on Cat. No. 3146A).

Cat. No.	Description	Length	Weight (lbs.)
3146	For 5/8" hardware. Large end has 29/32" and 1-3/32" openings. Small end has 5/8" and 13/16" openings.	13" (330 mm)	1.85
3146A	For 3/4" hardware. Large end has 1-1/16" and 1-5/16" openings. Small end has 5/8" and 7/8" openings.	13" (330 mm)	1.70



All dimensions are in inches and (millimeters).

▲WARNING: Always wear approved eye protection.

▲WARNING: Do NOT push or hammer wrench.

▲WARNING: NOT insulated. Plastic-dipped or slip-on plastic handles are NOT intended for protection against electrical shock.

▲WARNING: Do NOT extend handle length.



Cushion-Grip Screwdriver Sets

Features:

Cushion-Grip handle allows for greater torque and comfort.

Integral flanges inside handle provide solid, twist-resistant blade anchor.

Special heat-treated shank.

Precision-machined tip for exact fit.

Premium chrome-plated shank for smooth feel and corrosion resistance.

Patented Tip-Ident® quickly identifies the type of screwdriver and screwdriver tip orientation.

Meets or exceeds applicable ASME / ANSI specifications.

MADE IN USA

Keystone-Tip Screwdrivers – Heavy-Duty Round-Shanks

Additional Features:

- Built to handle the tough jobs with ease.
- Hex bolster reinforces shank for hard use and allows wrench assisted turning.

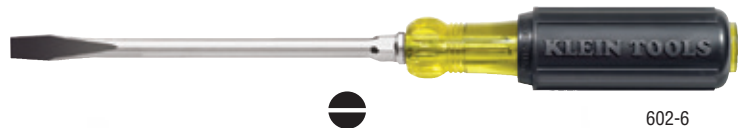

Cat. No.	Shank Tip Width	Shank Length	Overall Length	Weight (lbs.)
600-1*	1/4" (6 mm)	1-1/2" (38 mm)	3-7/16" (87 mm)	.10
602-3	7/32" (6 mm)	3" (76 mm)	6-3/4" (171 mm)	.15
602-4	1/4" (6 mm)	4" (102 mm)	8-11/32" (212 mm)	.25
602-6	5/16" (8 mm)	6" (152 mm)	10-15/16" (278 mm)	.35
602-8	3/8" (10 mm)	8" (203 mm)	13-7/16" (341 mm)	.55
602-10	3/8" (10 mm)	10" (254 mm)	15-7/16" (392 mm)	.60
602-12	3/8" (10 mm)	12" (305 mm)	17-7/16" (443 mm)	.65

* Bolster not available on 600-1.
Refer to the insulated section for insulated screwdrivers.

All dimensions are in inches and (millimeters).

▲WARNING: Always wear approved eye protection.

▲WARNING: NOT insulated. Will NOT protect against electrical shock.

▲WARNING: Do NOT use to pry or chisel.



Hammers

Lineman's Straight-Claw Hammer



832-32

- Heavy-duty, double-duty hammer drives lags and pulls big nails.
- Special high-carbon steel head with solid, octagon-shaped driving end and thick, strong claw.
- Straight-grain hickory handle, lacquered.

Cat. No.	Head Weight	Overall Length	Weight (lbs.)
832-32	32 oz. (907 g)	15" (381 mm)	2.50



Lineman's Double-Face Hammer



809-36

- Designed for pole-line work.
- Rugged and well-balanced, with the weight to drive lag bolts.
- Forged, tempered-steel head is only 3-3/4" (95 mm) long for use in tight areas.
- Identical faces with 1-3/4" (44 mm) round-crown driving surface and beveled edges.

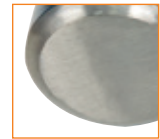

both sides

Cat. No.	Head Weight	Overall Length	Weight (lbs.)
809-36	36 oz. (1021 g)	14" (356 mm)	2.50

Lineman's Milled-Face Hammer



809-36MF

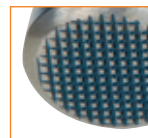

side 1



side 2

- One milled face for driving staples used in pole-line work and common, unhardened nails.
- Other face is smooth for driving heavier duty hardware.
- Rugged and well-balanced, with the weight to drive lag bolts.
- Forged, tempered-steel head is only 3-3/4" (95 mm) long for use in tight areas.

Cat. No.	Head Weight	Overall Length	Weight (lbs.)
809-36MF	36 oz. (1021 g)	14" (356 mm)	2.50

All dimensions are in inches and (millimeters) unless otherwise specified.

⚠WARNING: Always wear approved eye protection.



Pocket Knives – One Blade

Lightweight Lockback Knives

- Blades are AUS 8 stainless steel hardened to 58-59 Rc.
- Premium quality blade offers superior edge holding.
- Impact-resistant nylon resin handle with rubber insert (Cat. Nos. 44002-44005).
- Slim and comfortable silver anodized-aluminum handle for corrosion-resistance (Cat. Nos. 44000, 44001, 44006, 44007, 44008).
- Black chrome blade and black anodized-aluminum handle for corrosion-resistance (Cat. Nos. 44000-BLK and 44001-BLK).
- Cat. No. 44008 features drop point and screwdriver blades.
- Reversible thumb stud provides easy one-handed opening.



44001-BLK



44001



44002



44005

Cat. No.	Blade Steel	Blade Length	Closed Length	Weight (oz.)
Drop Point Blade				
44000	AUS 8 stainless steel	2-1/4" (57 mm)	3-1/8" (76 mm)	1.5
44000-BLK	AUS 8 stainless steel	2-1/4" (57 mm)	3-1/8" (76 mm)	1.1
44001*	AUS 8 stainless steel	2-1/2" (64 mm)	3-1/2" (89 mm)	2.5
44001-BLK*	AUS 8 stainless steel	2-1/2" (64 mm)	3-1/2" (89 mm)	1.3
44002	AUS 8 stainless steel	2-3/8" (60 mm)	3-1/2" (89 mm)	1.5
44003	AUS 8 stainless steel	2-3/4" (70 mm)	4-1/8" (105 mm)	2.5
Sheepfoot Blade				
44004	AUS 8 stainless steel	2-3/8" (60 mm)	3-1/2" (89 mm)	1.5
44005	AUS 8 stainless steel	2-5/8" (67 mm)	4-1/8" (105 mm)	2.5
44006*	AUS 8 stainless steel	2-5/8" (67 mm)	3-1/2" (89 mm)	1.3
Coping Blade				
44007*	AUS 8 stainless steel	2-1/2" (63 mm)	3-1/2" (89 mm)	1.5

* Includes a pocket/belt clip.



Compact Pocket Knives – Drop Point Blade

- Compact and lightweight knives.
- Stainless steel handles and blades for long life.
- Rosewood handle inserts on both sides.
- Modified spearpoint blades lock open.

Cat. No.	Blade Steel	Blade Length	Length Closed	Weight (oz.)
44032	stainless steel	1-5/8" (41 mm)	2-1/2" (64 mm)	1.0
44033	stainless steel	2" (51 mm)	3" (76 mm)	1.8
44034	stainless steel	2-5/8" (67 mm)	4" (102 mm)	4.0



44033

All dimensions are in inches and (millimeters).

▲WARNING: Always wear approved eye protection.

▲WARNING: Never use on or near live electrical circuits.



Pocket Knives – One Blade

Sportsman Knives – Sharp Point Blade

- Curved handle with big bolster.
- Brass bolsters and ebony wood handles.
- Stainless steel blades for long life.
- Brass linings.



- Blades lock open.
- Cat. No. 44037 furnished with leather snap case with belt loop.

44037

Cat. No.	Blade Steel	Blade Length	Length Closed	Weight (oz.)
44035	stainless steel	2" (51 mm)	3" (76 mm)	1.5
44036	stainless steel	2-3/8" (60 mm)	3-1/2" (89 mm)	2.5
44037	stainless steel	3-3/8" (86 mm)	4-7/8" (124 mm)	6.5

Pocket Knives – Coping Blade

- Coping-type blade.
- Compact and lightweight.
- Ideal for skinning small wire and cable.
- Blade locks open (Cat. No 1550-11 and 1550-14 only)



- Woodgrain plastic handle (Cat. No. 1550-14 only)

1550-14

Cat. No.	Blade Steel	Blade Length	Length Closed	Weight (oz.)
1550-5	carbon steel	2-1/4" (57mm)	3-1/4" (83mm)	1.5
1550-11*	carbon steel	2-1/4" (57mm)	3-1/4" (83mm)	1.5
1550-14*	carbon steel	3" (76mm)	4-1/4" (108mm)	4.0
1550-45	stainless steel	2-1/4" (57mm)	3-1/4" (83mm)	1.5

*Blade locks open

Pocket Knives – Sheepfoot Slitting Blade

- Extra-large curved sheepfoot slitting-blade – 2-5/8" (67 mm) long.
- Ideal for heavy-duty line work.
- Woodgrain plastic handle.
- Blade locks open.



1550-4

Cat. No.	Blade Steel	Blade Length	Length Closed	Weight (oz.)
1550-4	carbon steel	2-5/8" (67 mm)	4" (102 mm)	4.0
1550-44	stainless steel	2-5/8" (67 mm)	4" (102 mm)	4.0

Pocket Knife – Slitting Blade

- Large, stainless steel, curved-sheepfoot slitting blade – 2-1/2" (64 mm) long.
- Ideal for heavy-duty line work.
- Plastic handle.
- Blade locks open.



1550-24

Cat. No.	Blade Steel	Blade Length	Length Closed	Weight (oz.)
1550-24	stainless steel	2-1/2" (64 mm)	4-3/8" (111 mm)	2.5

Pocket Knives – Two Blades

2-Blade Pocket Knives – Spearpoint and Screwdriver-Tip Blades

- Standard spearpoint blade – 2-1/2" (64 mm) long.
- Screwdriver-tip blade – 2-1/2" (64 mm) long.
- Screwdriver-tip blade locks open.



1550-2

Cat. No.	Blade Steel	Blade Lengths	Length Closed	Weight (oz.)
1550-2	carbon steel	2-1/2" (64 mm)	3-3/4" (95 mm)	4.0
1550-42	stainless steel	2-1/2" (64 mm)	3-3/4" (95 mm)	4.0

2-Blade Pocket Knife – Sheepfoot and Screwdriver-Tip Blades

- Curved sheepfoot slitting blade – 2-3/8" (60 mm) long.
- Screwdriver-tip blade – 2-1/2" (64 mm) long.
- Screwdriver blade locks open.



1550-7

Cat. No.	Blade Steel	Blade Lengths	Length Closed	Weight (oz.)
1550-7	carbon steel	2-3/8" (60 mm) and 2-1/2" (64 mm)	3-3/4" (95 mm)	4.0

All dimensions are in inches and (millimeters).

▲WARNING: Always wear approved eye protection.

▲WARNING: Never use on or near live electrical circuits.



Sharpening Tools

Pocket-Sized Knife Sharpener

- A rugged, versatile sharpener featuring fine craftsmanship and unique design.
- Blade unscrews and stores in handle for convenient carrying in tool box, pouch, or pocket.
- Blade is precision-cut, hard-chromed steel for accurate, consistent sharpening and long life.
- Magnetized to trap metal particles when sharpening.
- Handle is high-visibility orange color, with handy pocket clip.



44151

Cat. No.	Blade Length	Length Closed	Weight (lbs.)
44151	3-3/4" (95 mm)	5-1/2" (140 mm)	.05

Special-Purpose Knives

Cable/Lineman's Skinning Knives



1560-3



1570-3

- Three-inch steel blade withstands frequent scoring and slitting of cable jacket.
- Blade and ring are securely molded in handle.
- Notch on blade back for scraping or removing wire insulation.
- Comfortable textured handle with finger grooves and guard.
- Heavy-duty serrated steel blade for saw-action cutting (Cat. No. 1560-3).
- No contact between stainless steel ring and hardened steel blade (available on Cat. No. 1570-3).
- Rectangle-shaped handle design for attachment to some utility hot stick equipment.
- Leather sheath available, Cat. No. 5163.



Cat. No.	Description	Handle Color	Length Less Ring	Weight (lbs.)
1560-3	serrated blade, notch, and ring	black	8" (203 mm)	.30
1570-3	hook blade, notch, and ring	red	8" (203 mm)	.30
1570-3LR	hook blade and notch	red	8" (203 mm)	.29

Cable-Sheath Splitting Knife



1515-S

- Compact, lightweight knife for opening lead cables.
- Rugged, forged tempered cutlery steel blade.
- Sharp, chisel-shaped edge.
- Hammer head on back.
- Plastic-dipped handle for comfort.
- Leather guard available, Cat. No. 5574S.

Cat. No.	Overall Length	Blade Length	Weight (lbs.)
1515-S	7-3/8" (187 mm)	2-19/32" (66 mm)	.35

Bell System Cable-Sheath Splitting Knife – Heavy-Duty



1515-1

- Heavy-duty knife for splitting cable sheaths.
- Rugged, forged tempered cutlery steel blade.
- Sharp chisel-shaped edge.
- Plastic-dipped handle for comfort.
- Leather guard available, Cat. No. 5574L.

Cat. No.	Overall Length	Blade Length	Weight (lbs.)
1515-1	8-3/4" (222 mm)	4-1/2" (114 mm)	1.20

All dimensions are in inches and (millimeters).

▲WARNING: Always wear approved eye protection.

▲WARNING: Never use on or near live electrical circuits.



Special-Purpose Knives

Cable-Splicer's Kits

- Cuts cable, telephone wire, and strips insulation.
- Dimensions: 2-1/8" x 7-1/2" (54 mm x 191 mm).

Cat. No.	Kit Contains	Weight (lbs.)
46037	cable splicer's kit	.50
Cat. No.	Description	
44200	cable-splicer's knife	
2100-7	electrician's scissors with stripping notches	
5187	slotted leather holder for belts up to 2" (51 mm) wide	



46037

Cable-Splicer's Knife

- Special-purpose short blade with comfortable, full-sized, heavy-duty handle.
- Coping-type blade made of the finest cutlery steel, tough and carefully tempered to hold its edge.
- Handle is textured for comfort and firm grip.
- Hang hole for easy storage and portability.

Cat. No.	Overall Length	Blade Length	Weight (lbs.)
44200	6-1/4" (159 mm)	1-3/4" (44 mm)	.15



44200

Electrician's Scissors

Electrician's Scissors

- Designed for telecom and electrical applications and heavy-duty use.
- Strong, tough tempered steel.
- Nickel-plated finish resists corrosion.
- Scraper and file on outside of both blades.



2100-5

Cat. No.	Overall Length	Cutting Length	Weight (lbs.)
2100-5	5-1/4" (133 mm)	1-7/8" (48 mm)	.20

Electrician's Scissors – Stripping Notches

- Upper blade has notches for stripping 19 AWG and 23 AWG wire.
- Designed for telecom and electrical applications and heavy-duty use.
- Strong, tough tempered steel.
- Nickel-plated finish resists corrosion.
- Scraper and file on outside of both blades.
- Serrated lower blade reduces slippage.



2100-7

Cat. No.	Overall Length	Cutting Length	Weight (lbs.)
2100-7	5-1/4" (133 mm)	1-7/8" (48 mm)	.20

Stainless Steel Electrician's Scissors – Stripping Notches

- Stainless steel blades to maintain blade durability and sharpness.
- Blade is fully serrated for non-slip cutting action.
- Free-fall snip feature for ease of use (2100-8).
- Cuts electrical communication 19 AWG and 23 AWG wire.
- Extended handle provides comfort and cutting leverage for wire cutting applications (2100-8).
- 56 HRC.



2100-9



2100-8

Cat. No.	Overall Length	Cutting Length	Weight (lbs.)
2100-8	6-5/16" (160 mm)	1-7/8" (48 mm)	.21
2100-9	5-1/4" (133 mm)	1-7/8" (48 mm)	.21

All dimensions are in inches and (millimeters).

▲WARNING: Always wear approved eye protection.

▲WARNING: Never use on or near live electrical circuits.

▲WARNING: NOT insulated. Will NOT protect against electrical shock.



Folding Rules

Fiberglass Folding Rules

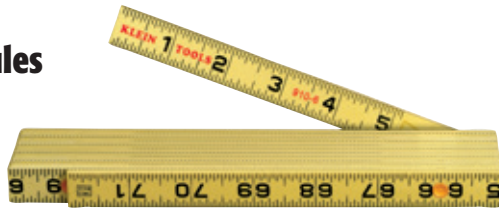

910-6

- Constructed of tough nylon, reinforced with glass fibers for added durability, and resistance to weather, abrasion, and most chemicals.
- Positive locking joints and stainless steel spring hinges for added strength.
- Measurements are marked on both sides and both edges, graduated to 1/16th inch.
- Black markings on yellow, with red stud center markings every 16 inches.
- Engraved graduations on both sides.

Cat. No.	Reading	Length	Weight (lbs.)
910-6	inside	6' (183 cm)	.33
911-6	outside	6' (183 cm)	.33

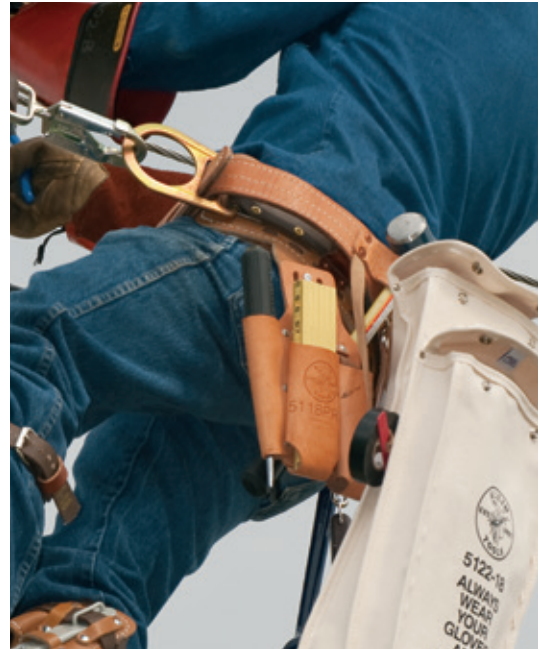

Fiberglass Tapes

Woven Fiberglass Tape – Case

- Woven fiberglass tape with moisture-proof coating of polyvinyl chloride assures durability and protects against oil or chemicals.
- Can be immersed in water without adverse effects.
- All metal parts are nickel-plated for protection against rust.
- End-hooks are permanently attached to reinforced strip.
- Black case and reel are ruggedly built, yet lightweight and comfortable to use.
- Tape line graduated in feet and inches to 8ths.
- Black graduating numbers and red foot markings on yellow background.
- Protective carrying case encloses tape completely.
- Tape ring tucks neatly into case opening for storage.

Cat. No.	Length	Width	Weight (lbs.)
946-50	50' (15 m)	1/2" (13 mm)	.80
946-100	100' (30 m)	1/2" (13 mm)	1.20



946-100

Gloves

Lineman Work Gloves

- 4" Neoprene cuff with side vents.
- Soft grain leather construction and reinforced leather patches for added flexibility.
- Double-row padded knuckle for durability and long life.

	Medium	Large	Extra-Large	Weight (lbs.)
Cat. No.	40080	40082	40084	.25

⚠WARNING: These gloves are not intended for energized electrical use.



40080

All dimensions are in inches and (millimeters) unless otherwise specified.

⚠WARNING: Always wear approved eye protection.



Lineman Buckets, Bags & Holders

Klein lineman buckets, bags and accessories have been trusted and recognized for decades for their durability and dependability. They are built for strength and to handle professional wear and tear.



Lineman Buckets,
Bags & Holders



Canvas Buckets

Features:

Rope handle reinforced with leather for water resistance and strength.

Durable, straight-wall and tapered-wall buckets are made of heavy-duty canvas.



The No. canvas refers to the canvas weight. No. 1 being the thickest and No. 8 being the thinnest.

High-density polyethylene top ring for strength and chemical resistance.

Leather-Bottom Buckets

Additional Features:

- No. 1 canvas.
- Leather reinforced bottom.
- Leather cuff extends 3" (76 mm) up the side.
- Inside pocket measures 8" x 8" (203 mm x 203 mm).
- Rope handle.



5104

Cat. No.	Top Diameter	Bottom Diameter	Height	Extra Features	Weight (lbs.)
5104	12" (305 mm)	12" (305 mm)	17" (432 mm)		2.71
5104S	12" (305 mm)	12" (305 mm)	17" (432 mm)	swivel snap (Cat. No. 2012)	2.93

Straight-Wall Buckets

Additional Features:

- No. 6 canvas.
- Black molded polypropylene bottom.
- Rope handle.



5106

Cat. No.	Diameter	Height	Extra Features	Weight (lbs.)
5106	9" (229 mm)	14" (356 mm)		1.51
5106P	9" (229 mm)	14" (356 mm)	two 7" x 7" (178 mm x 178 mm) inside pockets	1.62
5106S	9" (229 mm)	14" (356 mm)	swivel snap (Cat. No. 2012)	1.80

Wide-Opening Straight-Wall Buckets

Additional Features:

- No. 6 canvas.
- Black molded polypropylene bottom.
- Rope handle.

Cat. No.	Diameter	Height	Extra Features	Weight (lbs.)
5109	12" (305 mm)	15" (381 mm)		2.06
5109P	12" (305 mm)	15" (381 mm)	one 8" x 8" (203 mm x 203 mm) inside pocket	2.12
5109S	12" (305 mm)	15" (381 mm)	swivel snap (Cat. No. 2012)	2.35
5109PS	12" (305 mm)	15" (381 mm)	one 8" x 8" (203 mm x 203 mm) inside pocket and swivel snap (Cat. No. 2012)	2.40



5109

All dimensions are in inches and (millimeters).



Canvas Buckets

Tapered-Wall Buckets

Additional Features:

- No. 6 canvas.
- Black molded polypropylene bottom.
- Rope handle.



5113

Cat. No.	Top Diameter	Bottom Diameter	Height	Extra Features	Weight (lbs.)
5113	12" (305 mm)	9" (229 mm)	13" (330 mm)		1.55
5113S	12" (305 mm)	9" (229 mm)	13" (330 mm)	swivel snap (Cat. No. 2012)	1.84

Heavy-Duty Tapered-Wall Bucket

Additional Features:

- Tough No. 4 canvas.
- Black molded polypropylene bottom.
- Rope handle.
- Riveted leather glove strap.
- Equipped with Cat. No. 2012 swivel snap hook.



5103S

Cat. No.	Top Diameter	Bottom Diameter	Height	Extra Features	Weight (lbs.)
5103S	12" (305 mm)	9" (229 mm)	12" (305 mm)	swivel snap (Cat. No. 2012)	1.95

Heavy-Duty Tapered-Wall Buckets with Pockets

Additional Features:

- Tough No. 4 canvas.
- Black molded polypropylene bottom.
- Rope handle.
- Riveted leather glove strap.
- Equipped with Cat. No. 2012 swivel snap hook.

Cat. No.	Top Diameter	Bottom Diameter	Height	Pockets	Extra Features	Weight (lbs.)
5171PS	12" (305 mm)	9" (229 mm)	12" (305 mm)	4 outside pockets	swivel snap (Cat. No. 2012)	2.20
5172PS	12" (305 mm)	9" (229 mm)	12" (305 mm)	15 inside pockets	swivel snap (Cat. No. 2012)	2.35



5171PS



5172PS

Oval Bucket with 41 Pockets

Additional Features:

- No. 6 canvas.
- Black molded polypropylene bottom.
- Sisal-Rope handle.
- Equipped with Cat. No. 2012 swivel snap hook.
- Tripod suspension rope for greater stability.
- 26 pockets inside and 15 pockets outside.

Cat. No.	Length	Width	Height	Pockets	Extra Features	Weight (lbs.)
5152S	14" (356 mm)	7" (177 mm)	10" (254 mm)	26 inside pockets 15 outside pockets	swivel snap (Cat. No. 2012)	2.46



5152S

Oval Bucket with 15 Interior Pockets

Additional Features:

- No. 6 canvas.
- Black molded polypropylene bottom.
- Sisal-Rope handle.
- Equipped with Cat. No. 2012 swivel snap hook.
- Tripod suspension for greater stability.

Cat. No.	Length	Width	Height	Pockets	Extra Features	Weight (lbs.)
5144S	14" (356 mm)	7" (177 mm)	10" (254 mm)	15 inside pockets	swivel snap (Cat. No. 2012)	2.17



5144S

All dimensions are in inches and (millimeters).



Canvas Buckets

Aerial-Basket Oval Bucket with 15 Interior Pockets

Additional Features:

- No. 6 canvas.
- Black molded polypropylene bottom.
- Two nylon 66 polymer hooks (Cat. No. 5144H) supplied with Cat. No. 5144.

Cat. No.	Length	Width	Height	Pockets	Extra Features	Weight (lbs.)
5144	14" (356 mm)	7" (177 mm)	10" (254 mm)	15 inside pockets	two hooks (Cat. No. 5144H)	2.01
5144B	14" (356 mm)	7" (177 mm)	10" (254 mm)	15 inside pockets		1.5



5144

Hard Body Oval Buckets

- Fabric constructed of rugged denier polyester to resist wear and tear on the jobsite (Cat. No. 5144BHB14OS).
- Black molded polypropylene bottom with drain holes.
- Cat. No. 5144H hooks sold separately.



5144BHB



5144BHB14OS



5144BHHB

Cat. No.	Pockets	Handle	Color	Length	Height	Width	Weight (lbs.)
5144BHB	15	No	orange	14" (356 mm)	10" (254 mm)	7" (178 mm)	2
5144BHHB	15	Yes	orange	14" (356 mm)	10" (254 mm)	7" (178 mm)	2
5144BHB14OS	29	Yes	black	14" (356 mm)	10" (254 mm)	7" (178 mm)	3

Hard Body Oval Bucket with Knife Sheath

- Includes leather skinning knife sheath and 14 other interior pockets.
- Orange, non-conductive plastic exterior maintains bucket shape.
- Fabric constructed of rugged denier polyester to resist wear and tear on the jobsite.
- Black molded polypropylene bottom with drain holes.
- Cat. No. 5144H hooks sold separately.



5144HBS

Cat. No.	Interior Pockets	Handle	Color	Length	Height	Width	Weight (lbs)
5144HBS	15	Yes	orange	14" (356 mm)	10" (254 mm)	7" (178 mm)	2

All dimensions are in inches and (millimeters).





Aerial Aprons

Aerial Aprons

- Sewn-in magnet design won't catch on gloves (Cat. No. 51829M).
- Includes: ten hand tool pockets, two pouches, hammer loop and two drill bit holders.
- Two pouches reinforced with heavy duty rivets.
- Cat. No. 5144H hooks sold separately.



Sewn-in Magnet



51829

51829M

Cat. No.	IPockets	Magnet	Color	Length	Height	Weight (lbs.)
51829	18	No	orange	24" (609 mm)	23" (584 mm)	4
51829M	18	Yes	orange	24" (609 mm)	23" (584 mm)	4

Hooks

Swivel Snap Hook

Additional Features:

- This is **NOT** an occupational protective hook. **NOT** for human support.
- Bronze swivel snap hook made for use on canvas buckets.
- Maximum safe load is 150 lbs. (68 kg).



2012

Cat. No.	Length	Width	Weight (lbs.)
2012	4-3/8" (111 mm)	1-5/8" (41 mm)	.28

Hook for Aerial-Baskets

- All weather, durable, nylon 66 polymer.
- Most manufacturers' aerial basket trucks accommodate bucket hook.
- Replacement hook for both Cat. No. 5144 and Cat. No. 5169.



5144H

Cat. No.	Weight (lbs.)
5144H	.30

Slings

Pole Sling

- For use where a running loop wrap around pole is desired.
- Nylon web stitched with nylon thread.
- Copper rivets with burrs at the point of wear.
- **NOT** an occupational protective device. **NOT** for human support.
- Resistant to oil, creosote, and moisture.



5606

Cat. No.	Rated Capacity (Maximum Working Load)		Overall Length	Width	Weight (lbs.)
	Choke Hitch	Basket Hitch			
5606	3000 lbs (1350 kg)	4700 lbs (2115 kg)	39" (991 mm)	2" (51 mm)	1.33

All dimensions are in inches and (millimeters).

⚠WARNING: This is **NOT** an occupational protective device. **NOT** for human support.

All Purpose Bags

Tradesman Pro™ Organizers – Electrician's Backpack

- 39 pockets for tons of tool storage.
- Orange interior for easy tool visibility.
- Wide opening fits power drills, meters, flashlights, etc.
- Tough, durable bottom protects from the elements.
- Large front pocket easily fits fish tapes.
- 1680D ballistic weave for durability.

Cat. No.	Length	Width	Height	Interior Pockets	Exterior Pockets	Weight (lbs.)
55421-BP	14" (355.6 mm)	7" (177.8 mm)	18" (457.2 mm)	34	5	5.34



55421-BP

Large front pocket easily fits fish tapes or bulky tools.

Tradesman Pro™ Organizers – 10-Inch Tote

- 40 pockets for maximum tool storage.
- Orange interior for easy tool visibility.
- Removable zipper bag designed to fit compartment underneath.
- Tough, durable feet protect from the elements.
- 1680D ballistic weave for durability.
- Shoulder strap and handles for easy carrying.

Cat. No.	Length	Width	Height	Interior Pockets	Exterior Pockets	Weight (lbs.)
55416-10	10" (254 mm)	10" (254 mm)	12" (304.8 mm)	18	22	5.16



Removable zipper bag designed to fit compartment underneath.



55416-10



Tool Bags

Vinyl Equipment Bags

- Wide bag opening easily accommodates helmets and other equipment.
- Two large, outside pockets with Velcro® fastening (Cat. No. 5182BLA).
- Durable, double-stitched plastic bottom.
- Webbing extends down side of bag from handles and shoulder strap for extra support & durability.
- Right-sized rain flap with Velcro fastening.
- Adjustable, padded shoulder strap included.



5182BLA



5181ORA



Tool Bags

Cat. No.	Exterior Pockets	Shoulder Strap	Color	Length	Height	Width	Weight (lbs.)
5182BLA	2	Yes	black	24" (610 mm)	20" (508 mm)	10" (254 mm)	7.00
5181ORA	1	Yes	orange	24" (610 mm)	20" (508 mm)	10" (254 mm)	7.00

Extra-Large Vinyl Equipment Bag

- Orange vinyl-coated polyester fabric bag.
- Bottom extends 3" (76 mm) up the sides.
- Bottom of bag is protected by metal studs.
- Bottom reinforced with 1/4" (6 mm) plywood.
- Nylon-web handles extend around bag for extra support.
- Wide opening steel frame is securely riveted in top of bag.
- Extra flap for storm protection.

Cat. No.	Length	Width	Height/Depth	Weight (lbs.)
5180	24" (610 mm)	10" (254 mm)	18" (457 mm)	6.00



5180

All dimensions are in inches and (millimeters).



Tool Bags

Canvas Tool Bags

- Heavy-duty No. 8 natural canvas.
- Rivet-reinforced for durability.
- Steel-frame mouth with hinge for rugged use.
- Stitched and riveted leather handles for comfort and strength.
- Two retaining straps with buckles provide secure closure.
- Bottom and lower sides are covered with moisture-resistant vinyl.
- Non-scratch studs on base protect against wear.
- Shoulder strap kit available (Cat. No. 5102S).



5102-12

Cat. No.	Length	Width	Height/Depth	Weight (lbs.)
5102-12	12" (305 mm)	6" (152 mm)	10" (254 mm)	2.14
5102-14	14" (356 mm)	6" (152 mm)	14" (356 mm)	2.55
5102-16	16" (406 mm)	6" (152 mm)	14" (356 mm)	3.05
5102-18	18" (457 mm)	6" (152 mm)	14" (356 mm)	2.84
5102-20	20" (508 mm)	6" (152 mm)	15" (381 mm)	3.16
5102-22	22" (559 mm)	6" (152 mm)	15" (381 mm)	3.48
5102-24	24" (610 mm)	6" (152 mm)	15" (381 mm)	4.10

Zipper Bag



5139



5139B



5139C

- Constructed of No. 10 canvas with heavy-duty brass zipper.
- Convenient storage for pliers, wrenches, screwdrivers, nut drivers, other tools, and spare parts.
- Constructed of Cordura® ballistic nylon, a high-performance fabric resistant to abrasions, tears, and scuffs (Cat. Nos. 5139, 5139B, 5139C).
- Heavy-duty nylon zipper. (Cat. Nos. 5139B, 5139).
- Features the jungle stalker digitized camouflage pattern for maximum concealment (Cat. No. 5139C).
- Heavy-duty nylon stitching and zipper ensure durability and long life (Cat. No. 5139C).

Cat. No.	Material	Length	Height	Weight (lbs.)
5139	canvas	12-1/2" (318 mm)	7" (178 mm)	.19
5336	canvas	17" (432mm)	12" (305 mm)	.40
5139B	Cordura® Ballistic Nylon	12-1/2" (318 mm)	7" (178 mm)	.24
5236	Cordura® Ballistic Nylon	17" (432 mm)	12" (305 mm)	.51
5139C	Cordura® Camouflage	12-1/2" (318 mm)	7" (178 mm)	.14

Cordura® is a registered trademark of INVISTA for durable fabrics.



Tool Pouches

Extra-Large Canvas Utility Bag

- Heavy No. 8 natural canvas.
- Includes interior pocket.
- Inside bottom is reinforced with cushion leather & ventilating eyelet.
- Metal snaps provided on loops for easy attachment to belts up to 3" (76 mm) wide.
- Top edge reinforced with 1/4" (6 mm) rope.

Cat. No.	Belt Connection	Belt Capacity	Length	Width	Depth	Weight (lbs.)
5141P	loops	up to 3" (76 mm) wide	10" (254 mm)	12" (305 mm)	5" (127 mm)	.88



5141P

Canvas Utility Bags

- Heavy No. 8 natural canvas.
- Top edge reinforced with 1/4" (6 mm) rope.
- Metal snaps provided on loops for easy attachment to belts up to 3" (76 mm) wide.
- Inside bottom is reinforced with cushion leather & ventilating eyelet.
- Cat. No. 5142P version includes interior pocket.

Cat. No.	Belt Connection	Belt Capacity	Length	Width	Top Diameter	Weight (lbs.)
5142	loops	up to 3" (76 mm) wide	9" (229 mm)	10" (254 mm)	8" x 3" (203 mm x 76 mm)	.60
5142P	loops	up to 3" (76 mm) wide	9" (229 mm)	10" (254 mm)	8" x 3" (203 mm x 76 mm)	.65



5142

Nut & Bolt Pouch

- Includes interior pocket.
- Top sides of pouch reinforced with leather to maintain shape of pouch opening.
- Inside bottom is reinforced with leather and ventilating eyelet.
- Metal snaps provided on loops for easy attachment to belts up to 3" (76 mm) wide.
- Top edge reinforced with 1/4" (6 mm) rope.

Cat. No.	Interior Pockets	Color	Length	Width	Depth	Weight (lbs.)
51A	1	black	9" (229 mm)	10" (254 mm)	3.5" (9 mm)	1



51A

Bull-Pin and Bolt Bags

- No. 4 canvas or split-leather with double bottom.
- Bolt bag with bull-pin loop on each side.

Cat. No.	Belt Connection	Belt Capacity	Length	Width	Depth	Weight (lbs.)
Canvas						
5416	loops	up to 3" (76 mm) wide	5" (127 mm)	9" (229 mm)	10" (254 mm)	.85
5416T	tunnel	up to 3" (76 mm) wide	5" (127 mm)	9" (229 mm)	10" (254 mm)	.90
Leather						
5416L	tunnel	up to 3" (76 mm) wide	5" (127 mm)	9" (229 mm)	10" (254 mm)	1.10



5416



5416L

All dimensions are in inches and (millimeters).



Tool Pouches

Knife Holder

- *Leather construction.*
- *Designed for utility knives and Klein Cat. Nos. 44100 and 44105.*
- *Corners riveted and stitched for extra durability.*



5185

Cat. No.	Belt Connection	Belt Width	Overall Size	Weight (lbs.)
5185	slotted	up to 2-1/2" (64 mm)	2-5/8" x 8-1/4" (67 mm x 210 mm)	.11

Lineman's Knife Holder

- *Leather construction.*
- *Designed for Klein skinning knives Cat. Nos. 1570-3, 1570-3LR, and 1560-3.*
- *Riveted to assure long life.*



5163

Cat. No.	Belt Connection	Belt Width	Overall Size	Weight (lbs.)
5163	slotted	up to 2" (51 mm)	3-1/2" x 9-3/8" (89 mm x 238 mm)	.21

4 and 5 Pocket Pouches

- *Leather construction with double leather back for durability.*
- *Rivet hole for belt connection.*
- *Riveted to assure long life.*
- *Includes knife snap, pockets for pliers, most screwdrivers, 6' folding rule and open ended wrenches.*

Cat. No.	Pockets (Total No.)	Belt Connection	Approx. Overall Size	Weight (lbs.)
5118P5	5	rivet hole	10" x 11" (254 mm x 279 mm)	1.13
5118P4	4	rivet hole	8" x 11" (203 mm x 279 mm)	.91



5118P5



5118P4

Pliers, Folding Rule, Screwdriver, and Wrench Holder

- *Leather construction.*
- *No exposed rivets in back.*
- *Riveted to assure long life.*
- *Pockets for 7", 8", and 9" side-cutting pliers, most screwdrivers, 6' folding rules, and open-end wrenches from 9/16" to 13/16".*
- *Nickel plated alloy snap.*



5118C

Cat. No.	Pockets	Belt Connection	Belt Width	Overall Size	Weight (lbs.)
5118C	4	slotted	up to 2" (51 mm)	6-1/2" x 11" (165 mm x 279 mm)	.78

Pliers, Rule, and Screwdriver Holders

- *Leather construction.*
- *3 pockets for pliers, folding rule, and screwdriver.*
- *S5118PRS has a two-way knife snap.*
- *Riveted to assure long life.*
- *Pockets for 7", 8", and 9" side-cutting pliers, most screwdrivers, 6' folding rules, and open end wrenches from 9/16" to 13/16".*



5118PRS

Cat. No.	Belt Connection	Belt Width	Overall Size	Weight (lbs.)
5118PRS	slotted	up to 2" (51 mm)	6-3/4" x 10" (171 mm x 254 mm)	.49
S5118PRS	slotted	up to 2" (51 mm)	6-3/4" x 10" (171 mm x 254 mm)	.56





Lineman's Climbing Equipment

Klein Tools lineman's climbing equipment meets or exceeds applicable OSHA, ASTM, and CSA standards and provides the comfort and choices professionals depend on.



Introduction – Lineman’s Climbing Equipment

Klein manufactures a full line of lineman’s body belts and positioning devices (for positioning and limited fall restrict applications), designed to comply with OSHA criteria and applicable ASTM and CSA requirements.

The symbol shown in Figure 1 appears on warning and instruction tags attached to each body belt and positioning device identifying the Occupational Protective Equipment (OPE) function.

All individuals who use Klein lineman’s climbing equipment, must be instructed in how to use this equipment correctly. Also, they must read, understand, and follow all instructions and warnings packed with the product before each use.

Klein lineman’s body belts

- Available in full-floating, semi-floating, or fixed styles.
- They meet or exceed all OSHA regulations, which apply to positioning device systems, for power utilities (OSHA 1926.959) and telecommunications (OSHA 1910.268).
- They also meet or exceed standards ASTM F887 and CSA Z259.1.
- Each belt has a permanent tag, which identifies model number, serial number, size, and date of manufacture.

Klein positioning devices

- Positioning straps available with KG (elongated) and KL (standard) length snap-hooks.
- An Adjustable Positioning Lanyard (APL) with Length Adjusting Device – LAD (rope adjuster) 8’ (2.4m).
- They are designed to meet or exceed standards:
- CSA Z259.11 and ASTM F887 – APL and positioning straps.



Figure 1.

Lineman’s Body Belts

Types of Klein Lineman’s Body Belts

Full-Floating Belt: 5278N (5299N and 5282N) *Not pictured*

- Allows 4” (102 mm) lateral movement of the D-rings during use.
- D-rings easily adjust to lineman’s positioning changes on the pole. As a result, the positioning strap slides against the pole less frequently, and strap wear is reduced.



Cat. No. 5278N pictured

- Any load or pull on the D-rings will not bind tools in the tool loops.
- Does not allow lateral movement of the belt strap with the tool loops.



Cat. No. 5266N pictured

Semi-Floating Belt: 5266N

- Allows lateral movement of the belt strap with the tool loops prior to wearing the body belt.
- Any load or pull on the D-rings will not bind tools in the tool loops.

- Does not allow lateral movement of the D-rings.



Cat. No. 5268N pictured

Fixed Belt: 5268N

- Does not allow lateral movement of the D-rings or belt strap with the tool loops.

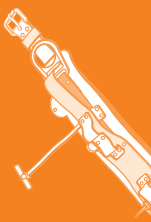

Introduction – Lineman's Climbing Equipment

Materials Used in Lineman's Climbing Equipment

Klein-Kord®

- Klein lineman's belt straps, billets, and pocket tabs are made of Klein-Kord®.
- Klein-Kord® is an exceptionally strong, multi-ply filament nylon fabric that is neoprene-impregnated, folded, and vulcanized.
- Klein-Kord® is abrasion-resistant, non-conductive, virtually free from stretch, and flexible for ease of use and durability. It has excellent chemical resistance and is virtually unaffected by creosote and other pole-treatment chemicals.
- In addition, its properties and wear characteristics remain essentially unchanged at temperatures up to 250°F (121°C).
- The center plies of Klein-Kord® are red at the core. When the red plies appear, remove the product from use and replace it. This "early warning" feature is yet another safety measure provided by Klein Tools.

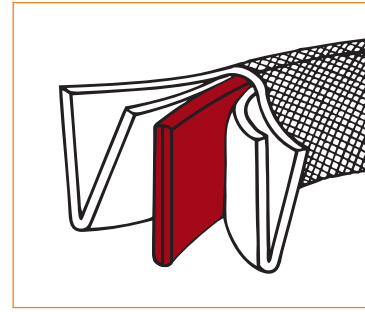

Six-ply Klein-Kord® with red center plies

Note: The red center plies may become discolored in use. Therefore, visual inspection for wear before use is mandatory.

Drop-Forged Steel Hardware

- Klein D-rings, snap-hooks, and tongue buckles are made of drop-forged steel with a corrosion-resistant finish.
- All of this Klein hardware is tested to meet or exceed applicable standards and OSHA requirements.

Nylon Webbing

- Klein uses a high-quality, commercial-grade nylon.
- The nylon webbing is impregnated with resin for extra durability and abrasion resistance.

Leather

- Rolled-edge, chrome-tanned topgrain leather is used for cushioning in all Klein lineman's belts. These cushions have sponge-rubber cores for added comfort.
- Other components, such as tool loops, are made of latigo leather, hand-laced and stitched to the belt cushion.
- Tape thong straps are constructed from topgrain leather with fiber cross-piece.
- On top-of-the-line belts, straps are covered with harness leather.

Nickel Plating

- Klein knife snaps, glove-bag rings, and suspender rings are nickel plated for durability and corrosion resistance.

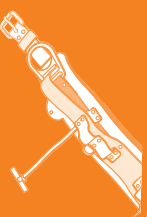

Lineman's Body Belts

Features:

Klein Tools body belts meet or exceed applicable ASTM and CSA standards and OSHA requirements.

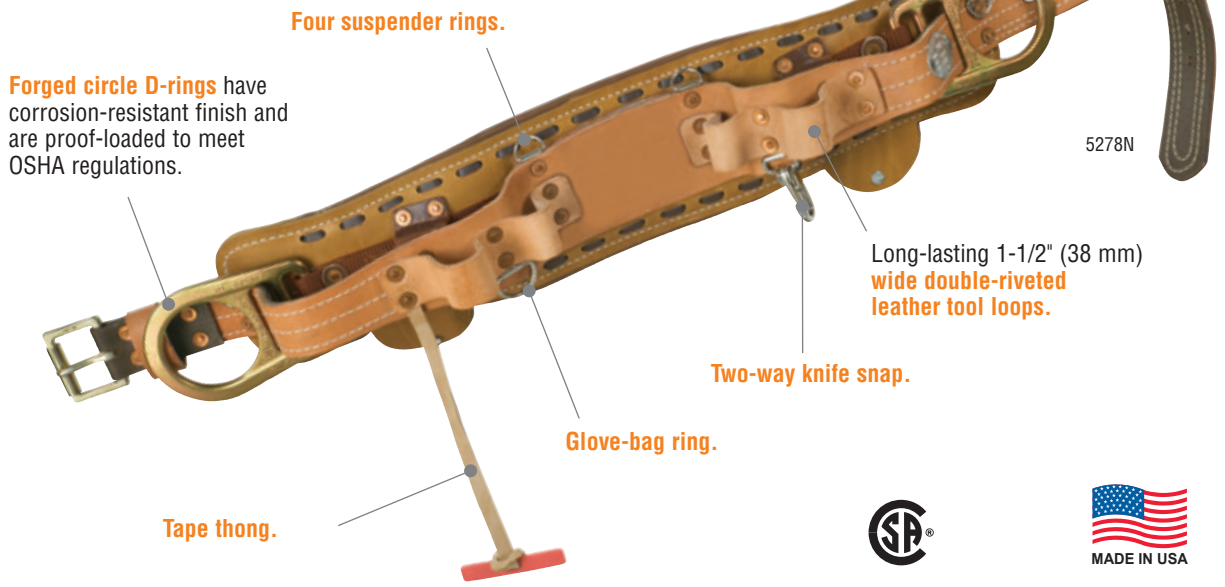

Full-Floating Body Belts

Lineman's Backsaver Belt



- *Leather construction is used throughout, including tool loops, tape thong, pocket tabs and cushioning material.*
- *Body Belt strap - covered in leather - is made of Klein-Kord®, an exceptionally strong nylon fabric that is abrasion-resistant, non-conductive, and flexible.*
- *4" (102 mm) lateral movement of D-ring independent of belt and pad.*
- *Meets or exceeds applicable OSHA requirements and ASTM and CSA standards.*

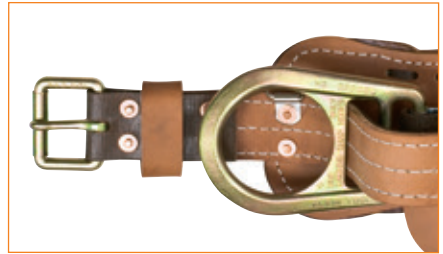

D-ring for 5299N

*See page 37 for body belt ordering procedure.



Full-Floating Body Belts

Full-Floating Body Belt – Style No. 5278N* (Deluxe) and Style No. 5282N* (Standard)

- *Latigo-leather belt pad is laced and stitched with two pocket tabs. (5278N only)*
- *Rolled-edge leather belt cushion for comfort when leaning back. 5" (127 mm) overall width.*
- *Padded for maximum comfort and body fit.*
- *1-3/4" (44 mm) wide Klein-Kord® belt strap covered with top-grain harness leather for long-lasting use.*
- *Full-floating D-ring web strap with straight double-bar D-rings.*
- *Klein-Kord® belt pad with two pocket tabs. (5282N)*



5278N



5282N



Positioning and Limited Fall Restrict

Semi-Floating Body Belt

Semi-Floating Body Belt – Style No. 5266N*

- *Klein-Kord® belt pad with two pocket tabs.*
- *Rolled-edge leather belt cushion for comfort when leaning back. 4-3/4" (120.6 mm) overall width.*
- *Padded for maximum comfort and body fit.*
- *1-3/4" (44 mm) wide belt strap made of 6-ply Klein-Kord®.*
- *Equipped with straight double-bar D-rings.*
- *Hand-line clip.*



5266N



Positioning and Limited Fall Restrict

Fixed Body Belt

Fixed Body Belt – Style No. 5268N*

- *Klein-Kord® belt pad with two pocket tabs.*
- *4-3/4" (120.6 mm) rolled-edge leather belt cushion with no padding.*
- *1-3/4" (44 mm) wide belt strap made of 6-ply Klein-Kord®.*
- *Equipped with straight double-bar D-rings.*



5268N



Positioning and Limited Fall Restrict

*See page 37 for body belt ordering procedure.

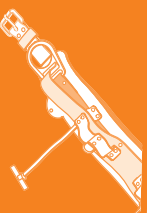

Positioning Straps

Klein-Gard™ (KG) and Klein-Lok™ (KL) Series Positioning Straps

- Made of 6-ply, 1-3/4" (45 mm) wide Klein-Kord® an exceptionally strong, flexible fabric.
- Elongated 6-1/2" (165 mm) snap hook is easy to use with even the thickest gloves. (KG Series)
- Internal lock mechanism.
- Snap hook has 5,000 lb. proof-loaded rating.
- Red wear indicator in center of strap alerts user when strap needs to be replaced.
- Meets or exceeds applicable OSHA requirements and ASTM and CSA standards.



KG5295L



Positioning Only

Cat. No. KG Series	Cat. No. KL Series	Maximum Length	Minimum Length	Adjustable Range
KG5295L	KL5295L	5' 8" (1.72 m)	4' 1" (1.24 m)	1' 7" (0.48 m)
KG5295-6L	KL5295-6L	6' (1.83 m)	4' 3" (1.30 m)	1' 9" (0.53 m)
KG5295-6-6L	KL5295-6-6L	6' 6" (1.98 m)	4' 6" (1.37 m)	2' (0.61 m)
KG5295-7L	KL5295-7L	7' (2.13 m)	4' 9" (1.45 m)	2' 3" (0.69 m)
KG5295-8L	KL5295-8L	8' (2.44 m)	5' 9" (1.75 m)	2' 3" (0.69 m)



KG Series 6-1/2" (165 mm) snap hook

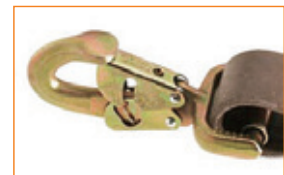

KL Series 5" (127 mm) snap hook

*Depending on the application, choose a positioning strap that allows you to work at arm's length from the pole or other positioning anchorage.

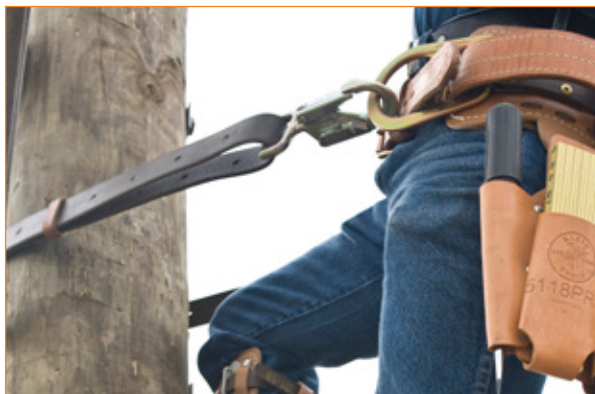

Klein has been a well-recognized manufacturer of occupational protective equipment since 1890.

The Klein-Gard™ positioning straps provide ease of use with gloved hands. The positioning straps are constructed with 6-ply Klein-Kord® material, which offers abrasive resistance and contrasting center color to alert lineman when to replace. The KG series features drop-forged hardware with a corrosion resistant finish.

⚠WARNING: It is important that users of this product read, understand, and follow all instructions, cautions, and warnings that are attached to and/or packed with the product.

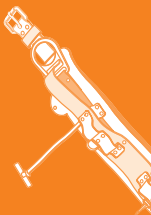

*See page 37 for body belt ordering procedure.

Body Belt & Back Saver Belt Ordering Procedure

The Lineman's Belt Sizing Table (shown below) contains more information on selecting the proper belt size. For non-standard sizes, please call the Klein Tools Sales Department at 1-800-553-4676.

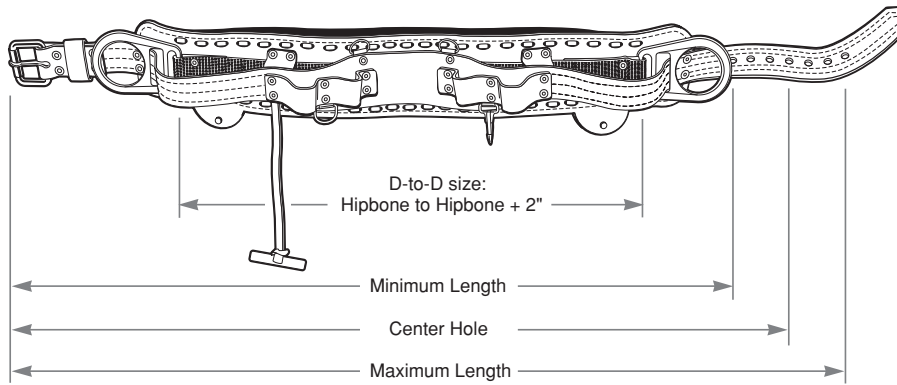

Lineman's Belt Sizing Table*

D-to-D Distance	Minimum Length	Center Hole Distance	Maximum Length
18D (46 cm)	32" (81 cm)	36" (91 cm)	40" (102 cm)
19D (48 cm)	33" (84 cm)	37" (94 cm)	41" (104 cm)
20D (51 cm)	34" (86 cm)	38" (97 cm)	42" (107 cm)
21D (53 cm)	36" (91 cm)	40" (102 cm)	44" (112 cm)
22D (56 cm)	37" (94 cm)	41" (104 cm)	45" (114 cm)
23D (58 cm)	38" (97 cm)	42" (107 cm)	46" (117 cm)
24D (61 cm)	40" (102 cm)	44" (112 cm)	48" (122 cm)
25D (64 cm)	41" (104 cm)	45" (114 cm)	49" (124 cm)
26D (66 cm)	42" (107 cm)	46" (117 cm)	50" (127 cm)
27D (69 cm)	44" (112 cm)	48" (122 cm)	52" (132 cm)
28D (71 cm)	45" (114 cm)	49" (124 cm)	53" (135 cm)
29D (74 cm)	46" (117 cm)	50" (127 cm)	54" (137 cm)
30D (76 cm)	47" (119 cm)	51" (130 cm)	55" (140 cm)

* All measurements are listed in inches and (cm). This table shows the maximum and minimum lengths and center-hole distances for the full range of standard D-to-D measurements. A belt sized for the proper D-to-D size will fit correctly with buckle tongue engaged in the center hole.

** Non-standard D-to-D sizes can be special ordered; please call the Klein Tools Sales Department at 1-800-553-4676.

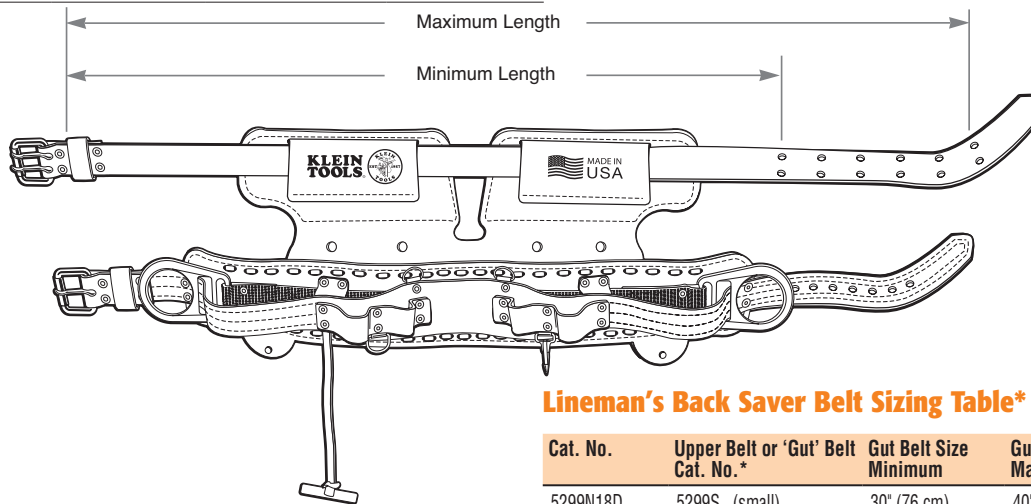

Lineman's Back Saver Belt Sizing Table*

Cat. No.	Upper Belt or 'Gut' Belt Cat. No.*	Gut Belt Size Minimum	Gut Belt Size Maximum
5299N18D	5299S (small)	30" (76 cm)	40" (102 cm)
5299N19D	5299 (medium)	34" (86 cm)	44" (112 cm)
5299N20D	5299 (medium)	34" (86 cm)	44" (112 cm)
5299N21D	5299 (medium)	34" (86 cm)	44" (112 cm)
5299N22D	5299 (medium)	34" (86 cm)	44" (112 cm)
5299N23D	5299L (large)	38" (97 cm)	48" (122 cm)
5299N24D	5299L (large)	38" (97 cm)	48" (122 cm)
5299N25D	5299L (large)	38" (97 cm)	48" (122 cm)
5299N26D	5299L (large)	38" (97 cm)	48" (122 cm)
5299N27D	5299XL (x-large)	42" (107 cm)	52" (132 cm)
5299N28D	5299XL (x-large)	42" (107 cm)	52" (132 cm)
5299N29D	5299XL (x-large)	42" (107 cm)	52" (132 cm)
5299N30D	5299XL (x-large)	42" (107 cm)	52" (132 cm)

CAUTION: Remember, a backsaver belt is not a substitute for an orthopedic brace and is only designed to provide the wearer additional comfort and support. The actual lineman's belt portion should still be worn around the hips. Do not position the belt lower and attempt to sit in it as you could flip or tip out in the event of a fall.



Body Belt Ordering Procedure

The catalog number used to order a Lineman's Body Belt is made up of specific parts. Each part of the number refers to a component or component size. The following is a typical example of a catalog number: 5278N-24D

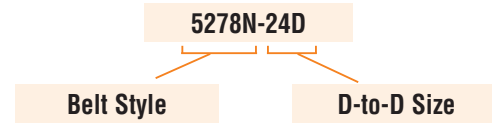

Use the following ordering procedure to properly identify and select each component in order to create a catalog number for your Lineman's Body Belt.

1. **Know the job and regulations** governing performance requirements for the equipment needed.
2. **Select the belt style.**

- Klein lineman's body belts are available in a choice of full-floating, semi-floating, and fixed styles, and feature the choice of belt pad size.
- All Klein lineman's body belts have chrome-tanned leather cushions for greater comfort.
- Full-floating belts allow lateral movement of the D-rings during use.
- Semi-floating and fixed-style belts allow no lateral movement of the D-rings.

3. **Select the proper belt size.**

- The comfort of a lineman's belt depends on the construction of the belt and the location of the D-rings.
- The D-rings should be located about 1" (25 mm) in front of the hip bones.

Never order Klein lineman's body belts by waist size. Always order Klein lineman's body belts by the desired distance between D-rings.

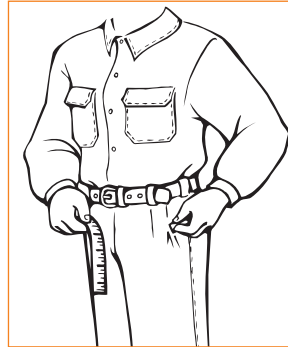

Size your body belt using a tape measure (Figure 1).

To obtain the correct D-to-D (D-ring to D-ring) size, measure around the back from hipbone to hipbone and then add 2" (51 mm).

Figure 1

Positioning Straps Ordering Procedure

Depending on your application, choose a positioning strap that allows you to work at arms' length from the pole or other positioning anchorage. Lineman's Positioning Straps are adjustable and available in five sizes. For more information, see the following chart:

Cat. No. KG Series	Cat. No. KL Series	Maximum Length	Minimum Length	Adjustable Range
KG5295L	KL5295L	5' 8" (1.72 m)	4' 1" (1.24 m)	1' 7" (0.48 m)
KG5295-6L	KL5295-6L	6' (1.83 m)	4' 3" (1.30 m)	1' 9" (0.53 m)
KG5295-6-6L	KL5295-6-6L	6' 6" (1.98 m)	4' 6" (1.37 m)	2' (0.61 m)
KG5295-7L	KL5295-7L	7' (2.13 m)	4' 9" (1.45 m)	2' 3" (0.69 m)
KG5295-8L	KL5295-8L	8' (2.44 m)	5' 9" (1.75 m)	2' 3" (0.69 m)

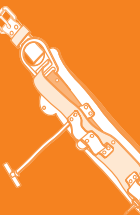
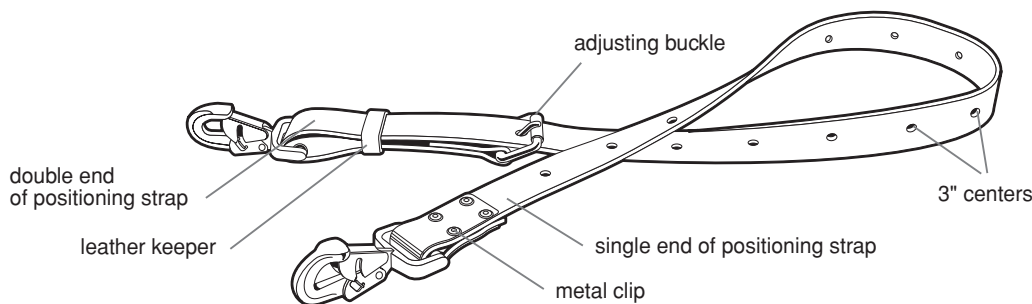
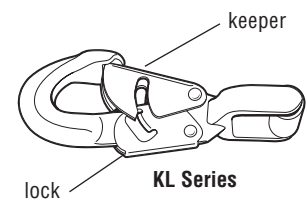
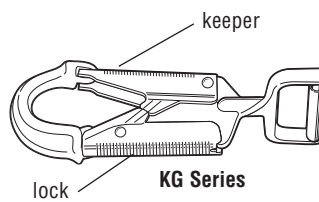

Pole & Tree Climbers

Features:



Adjustable climber length. Steel sleeve moves in 1/4" (6 mm) increments for the most comfortable fit.

Contoured leg irons help position gaffs securely and comfortably.

Replaceable gaff firmly attaches to the leg iron with a center pin and two TORX® screws.



8" x 8" (203 x 203 mm) cushioned, high-grade leather climber pads for maximum comfort.

Neoprene-impregnated nylon climber straps for long-lasting life.

Secure sleeve and leg iron connection. Two slotted hex-head bolts with lock washers and barrel-type nuts join the steel sleeve and leg iron together.

Steel split ring secures ankle strap in place and allows for quick replacement.

4-7/16" (113 mm) wide stirrup provides greater foot support.

Pole Climbers with 1-1/2" Gaffs - Complete Set

1972AR Series

- Includes 8" x 8" (203 x 203 mm) cushioned leather pad, steel sleeve, leg iron, gaff, split ring, and nylon calf and ankle straps.
- C.C.A. pole gaff. Designed to penetrate the hardest salt-treated poles.
- To determine size needed, measure from instep to 1" (25 mm) below knee.
- Sold in pairs only.



CN1972ARL

Cat. No.	Adjustable Length	Shipping Weight (lbs.)	Replacement Gaff Cat. No.	Replacement Pad Cat. No.	Replacement Calf Strap Cat. No.	Replacement Ankle Strap Cat. No.
CN1972AR	15" - 19" (381 mm - 483 mm)	6.00	72	8210	5301-18	5301-20
CN1972ARL	17" - 21" (432 mm - 533 mm)	6.25	72	8210	5301-18	5301-20

WARNING: For your protection, Klein recommends that climbers be replaced when original gaff and two replacement gaffs have been used on the climbers.

TORX® is a registered trademark of Acument Intellectual Properties, LLC. All Klein climber straps are sold in pairs only. All Klein ankle straps and pads are sold in pairs only.



Pole & Tree Climbers

Pole Climbers with 1-9/16" Gaffs – Complete Set

1986AR Series

- Gaffs are longer in length and wider in angle than 1-1/2" gaffs for exceptional resistance to cutouts.
- Includes 8" x 8" (203 x 203 mm) cushioned leather pad, steel sleeve, leg iron, gaff, split ring, and nylon calf and ankle straps.
- To determine size needed, measure from instep to 1" (25 mm) below knee.
- Sold in pairs only.

Cat. No.	Adjustable Length	Shipping Weight (lbs.)	Replacement Gaff Cat. No.	Replacement Pad Cat. No.	Replacement Calf Strap Cat. No.	Replacement Ankle Strap Cat. No.
CN1986AR	15" - 19" (381 mm - 483 mm)	6.20	86	8210	5301-18	5301-20
CN1986ARL	17" - 21" (432 mm - 533 mm)	6.35	86	8210	5301-18	5301-20



CN1986AR

Tree Climbers with 2-3/4" Gaffs – Complete Set

1907AR Series

- Extra-long gaffs for maximum penetration when climbing trees.
- Includes 8" x 8" (203 mm x 203 mm) cushioned leather pad, steel sleeves, leg iron, gaff, split ring, and nylon calf and ankle straps.
- To determine size needed, measure from instep to 1" (25 mm) below knee.
- Sold in pairs only.

Cat. No.	Adjustable Length	Shipping Weight (lbs.)	Replacement Gaff Cat. No.	Replacement Pad Cat. No.	Replacement Gaff Cat. No.	Replacement Ankle Strap Cat. No.
CN1907AR	15" - 19" (381 mm - 483 mm)	6.20	07	8210	5301-18	5301-20
CN1907ARL	17" - 21" (432 mm - 533 mm)	6.75	07	8210	5301-18	5301-20



CN1907AR

Pole Climbers Without Pads and Straps

- **POLE CLIMBERS ONLY.** Includes steel sleeve, leg iron, split ring, and gaff.
- To determine size needed, measure from instep to 1" (25 mm) below knee.
- Sold in pairs only.

Cat. No.	Adjustable Length	Shipping Weight (lbs.)	Replacement Gaff Cat. No.	Gaff Length
1972AR	15" - 19" (381 - 483 mm)	4.50	72	1-1/2" (38 mm)
1972ARL	17" - 21" (423 - 533 mm)	4.85	72	1-1/2" (38 mm)
1986AR	15" - 19" (381 mm - 483 mm)	4.50	86	1-9/16" (40 mm)
1907AR	15" - 19" (381 - 483 mm)	4.85	07	2-3/4" (70 mm)
1907ARL	17" - 21" (423 - 533 mm)	4.95	07	2-3/4" (70 mm)



1972AR



1986AR



1907AR

WARNING: For your protection, Klein recommends that climbers be replaced when original gaff and two replacement gaffs have been used on the climbers.

TORX® is a registered trademark of Acument Intellectual Properties, LLC. All Klein climber straps are sold in pairs only. All Klein ankle straps and pads are sold in pairs only.



Climber Accessories

Klein Velcro® – Climber Pads

- 4" of Velcro provides the maximum amount of adjustability.
- Continuous wrap with metal cinch loop for quick attachment and ease of use.
- Extra wide cuff fastens around the calf to provide more support.
- Padded for additional comfort.

Cat. No.	Description	Weight (lbs.)
8220	8220L (left) 8220R (right) only sold in pairs	1.75

Velcro® is a registered trademark of Velcro Industries B.V.

⚠WARNING: It is important that users of this product read, understand, and follow all instructions, cautions and warnings that are attached to and/or packed with this product.



8220

Climber Replacement Parts & Accessories

Snap-On Gaff Guard

- Coil-spring, plastic coated guard quickly snaps onto pole climbers.
- Sold in pairs only.



1972G

Removable Gaff Guard

- Long-lasting leather construction with easy-to-remove Velcro® strap.
- Sold in pairs only.



1945G

Cat. No.	Description	Shipping Weight (lbs.)
1972G	Snap-on gaff guards for pole climbers	.10

Cat. No.	Description	Shipping Weight (lbs.)
1945G	gaff guards for pole and tree climber	.10

Climber Straps for Pole and Tree Climbers



5301-18

- Durable neoprene-impregnated nylon strap is chemical/abrasion resistant and non-conductive.
- Tongue buckle has roller for easy adjustment.
- Sold in pairs only.

Cat. No.	Overall Size	Shipping Weight (lbs.)
5301-18	1" x 22" (25 mm x 56 cm)	.35
5301-20	1" x 26" (25 mm x 66 cm)	.40
5301-21	1-1/4" x 22" (32 mm x 56 cm)	.50
5301-22	1-1/4" x 26" (32 mm x 66 cm)	.46

Ankle Straps for Pole and Tree Climbers



5301-20

- Sold in pairs only.

- Durable neoprene-impregnated nylon strap is chemical/abrasion resistant and non-conductive.
- Tongue buckle has roller for easy adjustment and a comfortable leather buckle pad.

Cat. No.	Overall Size	Shipping Weight (lbs.)
5301-20	1" x 24" (25 mm x 61 cm)	.50
5301-23	1-1/4" x 24" (32 mm x 61 cm)	.70

⚠WARNING: For your protection, Klein recommends that climbers be replaced when original gaff and two replacement gaffs have been used on the climbers.

TORX® is a registered trademark of Acument Intellectual Properties, LLC. All Klein climber straps are sold in pairs only. All Klein ankle straps and pads are sold in pairs only.



Block and Tackle

- These are NOT occupational protective devices. NOT for human support.
- Light, galvanized-steel shell blocks are fitted with snubbing hooks to hold the load.
- Sheaves are strong, yet are lightweight aluminum alloy with all-bronze bushings.
- Available with standard snap hooks or guarded snap hooks (with snap hook nose lengthened to extend over the latch or keeper).
- Choice of forged hook Cat. No. 258 or swivel hook Cat. No. 259.
- Hooks fit under insulator and engage pin on cross arm.
- All Klein block and tackle use high-quality, 3/8" diameter rope.
- Catalog numbers followed by S/R have rope spliced to block.
- Maximum safe load is 750 lbs. (338 kg).

Block and Tackle with Standard Hooks

Cat. No.	Component Part Number			Rope spliced to component number	Weight (lbs.)
	267 Block	268 Block	258 Anchor Hook		
1802-30	●	●	●		2.80
1802-30 S/R	●	●	●	268 Block	2.80
1802-30S	●	●			2.85
1802-30S S/R	●	●		268 Block	2.85

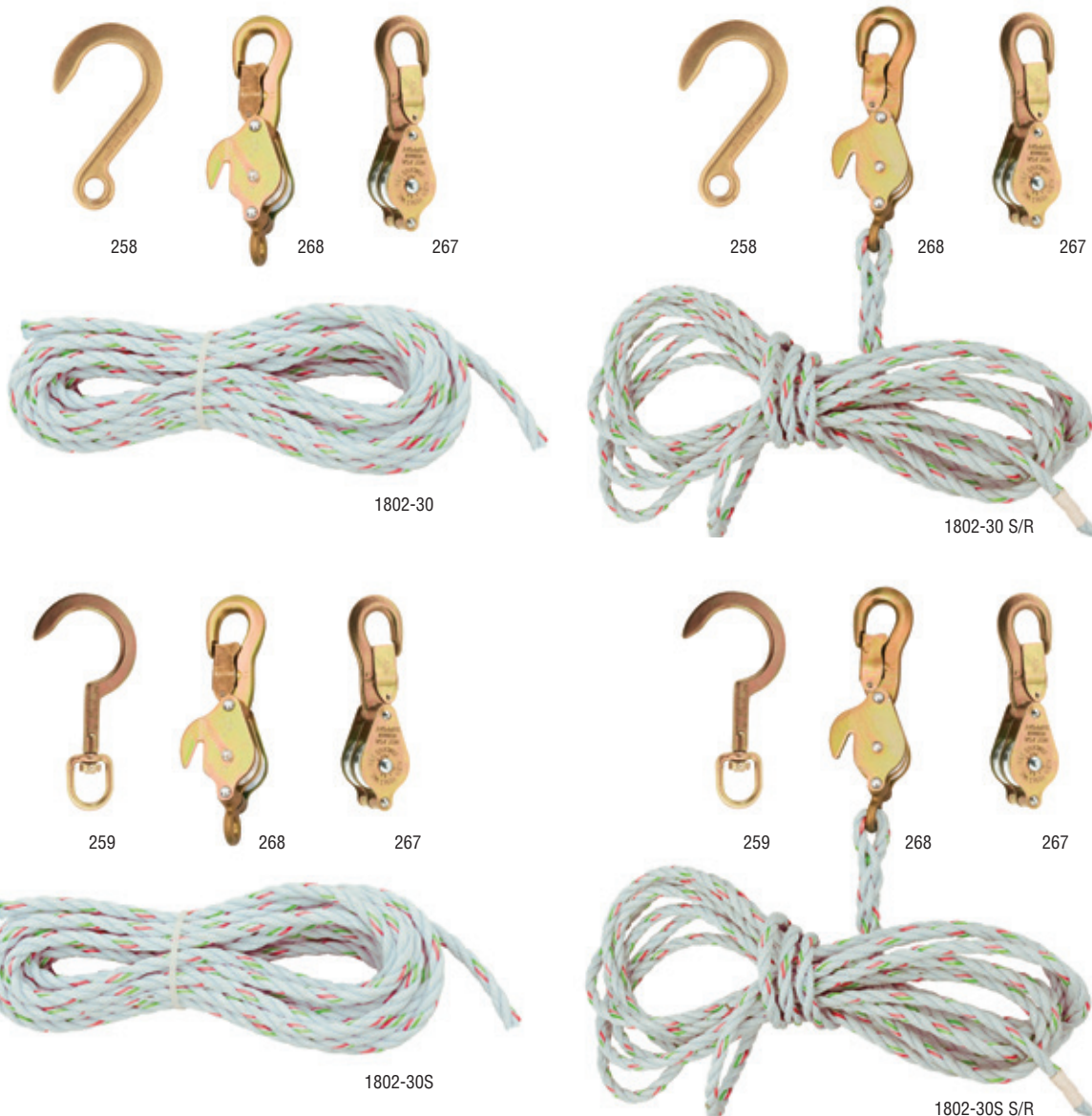

All dimensions are in inches and (millimeters).

⚠WARNING: These are NOT occupational protective devices. Do NOT use for human support.



Block and Tackle

Block and Tackle with Guarded Hooks



Cat. No.	Component Part Number				Rope spliced to component number	Weight (lbs.)
	H267 Block	H268 Block	258 Anchor Hook	259 Swivel Anchor Hook		
H1802-30	•	•	•			2.90
H1802-30 S/R	•	•	•		H268 Block	2.90
H1802-30 S	•	•		•		3.00
H1802-30S S/R	•	•		•	H268 Block	3.00



258 H268 H267



H1802-30



258 H268 H267



H1802-30 S/R



259 H268 H267



H1802-30S



259 H268 H267



H1802-30S S/R

All dimensions are in inches and (millimeters).

WARNING: These are NOT occupational protective devices. Do NOT use for human support.



Block and Tackle

Anchor Hook



- Forged hook is designed to slip under insulator and engage pin of cross arm.
- Maximum safe load 750 lbs. (340 kg).
- Standard on Klein block & tackle Cat. Nos. 1802-30 and H1802-30.

Cat. No.	Eye I.D.	Throat Opening	Overall Length	Weight (lbs.)
258	5/8" (16 mm)	1-7/8" (48 mm)	5-1/2" (140 mm)	.42

Swivel Anchor Hook



- Swivel clevis on this forged hook will engage with snap on Klein block & tackle Cat. Nos. 1802-30 and H1802-30.
- Swivel prevents twisting and kinking of rope.
- Maximum safe load 750 lbs. (340 kg).

Cat. No.	Swivel Opening	Throat Opening	Overall Length	Weight (lbs.)
259	1-3/16" x 1" (30 mm x 25 mm)	1-7/8" (48 mm)	6-1/2" (165 mm)	.40

Heavy-Duty Snap Hook

- Snaps on with one hand.
- Forged hook may be used on many conventional steel blocks, 4" (102 mm) or smaller.
- Maximum safe load 8000 lbs. (3629 kg).

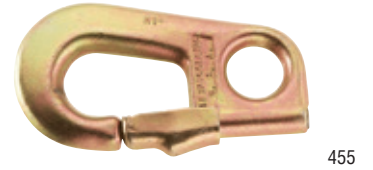

Cat. No.	Eye I.D.	Throat Opening	Overall Length	Weight (lbs.)
455	15/16" (24 mm)	1" (25 mm)	5" (127 mm)	.84

Blocks



267



268



H267



H268

- Blocks without ropes and hooks.
- Made of light galvanized steel and aluminum alloy.
- Sheaves have bronze bushings.

Cat. No.	Description	Weight (lbs.)
267	plain block	.76
H267	Cat. No. 267, but nose extends over keeper	.80
268	block with eye to splice line to block and rope tie-off	.91
H268	Cat. No. 268, but nose extends over keeper	1.00

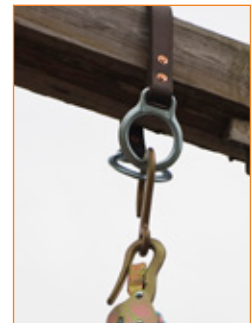

All dimensions are in inches and (millimeters).

⚠WARNING: These are NOT occupational protective devices. Do NOT use for human support.



Block and Tackle

Polypropylene Hand-Lines with Snap Hook



1804-60

- Made of 5/16" (8 mm) three-strand polypropylene rope spliced to eye of snap hook.
- Both lines 75' (23 m) long.
- Forged steel with swivel clevis and quick-acting plunger-style latch.

Cat. No.	Description	Weight (lbs.)
1803-60	75' (23 m) of 5/16" (8 mm) rope with Cat. No. 443A snap. Maximum safe load 250 lbs. (113 kg)	2.45
1804-60	75' (23 m) of 5/16" (8 mm) rope with Cat. No. 470 swivel snap. Maximum safe load 250 lbs. (113 kg)	2.20

Howe Wire Tool

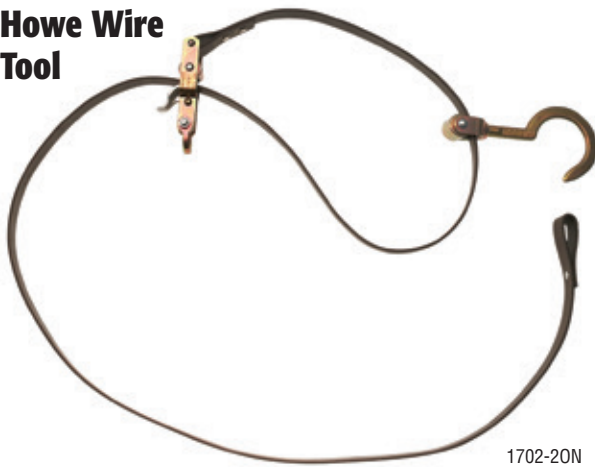

1702-20N

- Strap is made of tough Klein-Kord®.
- Swivel hook is forged steel with large opening.
- Shank of hook is lengthened to reach under insulator.
- Other end has device to hold the load at any distance.
- All metal parts are galvanized.
- Max. safe load 500 lbs. (225 kg).

Cat. No.	Description	Weight (lbs.)
1702-20N	nylon strap 1" (25 mm) wide, 7' (2.1 m) long	1.95

Snap Hook



443A

- General-purpose forged snap hook with eye at 90° to opening.
- Maximum safe load 1500 lbs. (675 kg).

Cat. No.	Eye I.D.	Throat Opening	Overall Length	Weight (lbs.)
443A	1" (25 mm)	1/2" (13 mm)	5-1/2" (140 mm)	.52

Swivel Hook with Plunger Latch

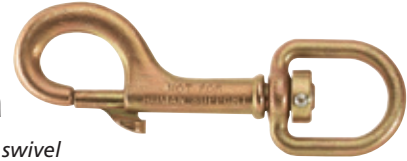

470

- Forged steel with swivel clevis and quick-acting plunger-style latch.
- Designed to take 1/2" (13 mm) or lighter hand lines.
- Swivel action prevents accidental fouling into secondary wires.
- Maximum safe load 750 lbs. (338 kg).

Cat. No.	Swivel Opening	Throat Opening	Overall Length	Weight (lbs.)
470	1-3/16" x 1" (30 mm x 25 mm)	5/8" (16 mm)	5" (127 mm)	.30



Howe Wire Tool



Howe Wire Tool

All dimensions are in inches and (millimeters).

⚠WARNING: These are NOT occupational protective devices. Do NOT use for human support.



Professional Series Multimeters

Electrician's / HVAC TRMS Multimeter

- Display Brighter than most competitive units
- Bar Graph measures fast moving readings
- Low Impedance reduces ghost voltage
- μ A setting for checking Flame sensors
- True RMS accurate readings for all signals
- 10A AC/DC Current
- Double Insulated
- Rubber Molding for drop protection
- Temperature
- Lead Storage protects leads
- 1000V Voltage reading
- CAT IV Safety Rating safest rating available

SPECIFICATION	MM2000
\tilde{A} AC Current	10A
\bar{A} DC Current	10A
\tilde{V} AC Voltage	1000V
\bar{V} DC Voltage	1000V
Ω Resistance	40M Ω
$\mu\tilde{A}$ Micro Amps	$\geq 0.1\mu\text{A}$
$\text{--}\text{ }\text{--}$ Capacitance	4000 μF
$^{\circ}\text{C}$ Temperature	-58 ~ 1832 $^{\circ}\text{F}$
$\text{Hz}/\%$ Frequency / Duty Cycle	1MHz
\blacktriangleright Diode Test	●
$\text{oi})$ Continuity	●
$\text{--}\text{ }\text{--}$ Battery Test	—
CAT Rating	CAT IV 600V



Backlit Display



Measure Large Capacitors



Magnetic Hanger Accessory



MM2000



E321008 3TMV

Cat. No.	CAT Rating	Batteries	Height	Width	Depth	Weight (oz.)	Included Accessories
MM2000	CAT IV 600V	2 x AAA	7.00" (178 mm)	3.50" (89 mm)	1.875" (48 mm)	14.0 (397 g)	test leads, batteries, thermocouple

	Cat. No.	Type
Replacement Fuses for MM1000 and MM2000	69192	F 440mA / 1000V
	69191	F 11A / 1000V



Professional Series Clamp Meters

1000A AC/DC TRMS Clamp Meter

- Extra Large Round Jaw opening
- True RMS accurate readings for all signals
- Non-contact Voltage Tester
- Capacitance for HVAC work
- Backlit Display is brighter than most competitive units
- Analog Bar Graph measures fast moving readings
- Worklight in jaw area
- Magnetic Mount secures meter and frees hands
- Side Mounted Dial for ease of use
- Lead Storage protects leads

CAT IV



CL2500

SPECIFICATION	CL2500
\tilde{A} AC Current	1000A
\bar{A} DC Current	1000A
\tilde{V} AC Voltage	750V
\bar{V} DC Voltage	1000V
\square LCD Display	6000
Ω Resistance	60M Ω
C Capacitance	6000 μF
HOLD Data Hold	●
AUTO Auto Ranging	●
Apo Auto Power-Off	●
Hz% Frequency / Duty Cycle	●
\rightarrow Diode Test	●
 Audible Continuity	●
NCV Non Contact Voltage	●
Δ Safety Rating	CAT IV 600V



Worklight



Extra Large Round Jaw Opening



Lead Storage



Cat. No.	CAT Rating	Batteries	Jaw Size	Height	Width	Depth	Weight (oz.)	Included Accessories
CL2500	CAT IV 600V	2 x AAA	1.97" (50 mm)	8.09" (205 mm)	2.56" (65 mm)	1.38" (35 mm)	13.6 (386 g)	test leads, batteries, case

Electronic Voltage Testers

- Measures AC and DC voltage at 9 common levels up to 600V.
- Bright LEDs indicate voltage reading without batteries installed.
- Low impedance input reduces possibility of ghost voltages.
- Permanently secured test leads are always there when they are needed.
- Molded lead holders are perfect for easy measurements of tamper-proof outlets.
- Vibration and sound alerts for dangerous voltage levels.
- Modern solid-state construction provides CAT IV 600V safety rating.

Additional Features for Cat. No. ET200

- Bright worklight to illuminate your work space.
- Audible continuity alerts at less than 270kΩ.

Standards:

UL 61010-1 2nd edition
 UL 61010-31 2nd edition
 CAN/CSA C22.2 No. 61010-01
 CAN/CSA C22.2 No. 61010-031



Double Insulated



ET200

Cat. No.	CAT Rating	Batteries	Height	Width	Depth	Weight (oz.)
ET100	CAT IV 600V	3 x AAA	7.375" (187 mm)	2.375" (60.3 mm)	1.25" (31.8 mm)	8.1 (230 g)
ET200	CAT IV 600V	3 x AAA	7.375" (187 mm)	2.375" (60.3 mm)	1.25" (31.8 mm)	8.1 (230 g)



Electrical Testers

Non-Contact Voltage Testers (NCVT-1/NCVT-2)

- Non-contact detection of standard voltage in cables, cords, circuit breakers, lighting fixtures, switches, outlets, and wires.
- High intensity, bright green LED indicates the tester is operational and aids in illuminating the workspace.
- Digitally controlled ON/OFF power button.
- Auto power-off feature conserves and extends battery life.
- Microprocessor controlled low-battery indicator.
- CAT IV 1000 Volt rating provides expanded operation and protection.
- Lightweight durable polycarbonate plastic resin construction with a convenient pocket-clip.
- Package contains insert card w/ integrated owner's manual and 2 AAA 1.5 volt batteries.



NCVT-1



Additional Features for Dual Range NCVT-2

- Automatically detects and indicates low voltage (12-48 Volts AC) and standard voltage (48-1000 Volts AC), allowing broad application.
- Non-contact detection of low-voltage in security, entertainment, communications, environmental control, and irrigation systems.

Voltage Range	12 TO 48 VOLTS AC (Low) (NCVT2 only)	48 TO 1000 VOLTS AC (Standard)
Audible	Low-Pitched Pulsing Beeping Sound	High-Pitched Continuous Beeping Sound
Visual	Green LED Turns OFF and Red LED Blinks (approximately 2-times per second).	Green LED Turns OFF and Red LED illuminates continuously.



NCVT-2



Standards:

UL 61010-1 2nd edition
 CAN/CSA C22.2 No. 610101-04
 EN 61010-1 2nd edition
 IEC 61010-1:2001 2nd edition
 ISA-82.02.01 (IEC 61010-1 MOD)



Cat. No.	Voltage Range	Frequency Range	Pollution Degree	Batteries	Overall Length	Width	Height	Weight (oz.)	Weight w/ Batteries (oz.)
NCVT-1	50-1000 volts AC	50-500 Hz	2	2 x AAA	5.50" (140 mm)	0.72" (18 mm)	1.0" (25 mm)	0.8 (23 g)	1.6 (46 g)
NCVT-2	12-1000 volts AC	50-500 Hz	2	2 x AAA	5.50" (14.0 cm)	0.72" (1.8 cm)	1.0" (2.5 cm)	0.8 (23 g)	1.6 (46 g)

⚠ WARNINGS:

- It is important that users of this tester read, understand, and follow all warnings, cautions, safety information, and instructions in the manual before operating or servicing this tester. Failure to follow instructions could result in death or serious injury.
- Risk of electric shock and burn. Contact with live circuits could result in death or serious injury.
- Use caution with voltages above 30V AC as a shock hazard may exist.
- A blinking or steady red glow and an audible beep indicate voltage present. If no indication, voltage could still be present.
- In bright light conditions, the LED visual indicators will be less visible.
- Do not use if green LED is not illuminated.

⚠ WARNINGS:

- Do not use if tester appears damaged or if the tester is not operating properly. If in doubt, replace the tester.
- Do not apply more than the rated voltage as marked on the tester (1000 volts AC).
- Always wear approved eye protection.
- Before each use, verify operation by testing a known working circuit that is within the rating of this tester.
- Do not rely on this tester with shielded wire. Operation may be affected by differences in socket design and insulation thickness and type.
- Comply with local and national safety requirements.
- If this tester is used in a manner not specified by the manufacturer, protection provided by the tester may be affected.

⚠ CAUTION: Do not attempt to repair this tester. It contains no serviceable parts. Do not expose the product to extremes in temperature or high humidity.



Important information for everyone who uses hand tools...fully illustrated pages of basic facts and practical "how-to" tips.



Prepared by KLEIN TOOLS in conjunction with the Hand Tools Institute. Available from your Klein distributor (Cat. No. 98016).

Warranty

Klein products in this catalog, manufactured and sold for commercial or industrial uses, are warranted to be free from defects in materials and workmanship for the normal life of the product, with the exception of: I. Electronic Test & Measurement products (see warranty below); and II. Ratcheting and Drill-Operated Cable Cutters, which are warranted for one year from the date of purchase. The following consumable products are warranted to be free from defects in materials and workmanship when delivered to the customer: Triple-Taps, Drill Bits, Step Drills, Carbide Hole Cutters, Hole Saws and Arbors; Saw Blades and Jab Saws; disposable Razor and Knife Blades; Stripper Cartridges, Replaceable Cutting Inserts, Bits and Blades; Hand Cleaners and Wire Pulling Lubricant. **THERE ARE NO IMPLIED WARRANTIES OF MERCHANTABILITY OR FITNESS.** At its option Klein will repair or replace, or refund the purchase price of, any product which fails to conform to this warranty under normal use and service. **In no event shall Klein be liable for incidental or consequential damage.**

If your Klein product requires repair or for information on how to exercise your rights under the terms of this warranty, please contact **Klein Tools at 1-800-553-4676.**

Electronic Test & Measurement Warranty

Klein electronic test and measurement devices (and accessories), manufactured and sold for commercial or industrial uses, are warranted to be free from defects in materials and workmanship for two years from the date of purchase (unless otherwise noted on the product packaging). **THERE ARE NO IMPLIED WARRANTIES OF MERCHANTABILITY OR FITNESS.** At its option, Klein will repair or replace, or refund the purchase price of, any product which fails to conform to this warranty under normal use and service. **In no event shall Klein be liable for incidental or consequential damage.** This warranty does not apply to batteries.

Warranty Returns

All warranty returns must include a Warranty Return Authorization (WRA) number. The WRA for the U.S. can be obtained by calling Customer Service at 1-800-553-4676. (International call 1-847-821-5500) or email serviceonline@kleintools.com.

Specifications of all products in this catalog are subject to Change without notice.

Dimensions shown for all forged products in this catalog are as precisely accurate as possible, but subject to very slight variations that are unavoidable in forging and grinding operations. Dimensions of Klein forged tools and all other tools and equipment are always within commercial tolerances recognized for such products.

Also available from Klein®...



Authentic Klein® Grips are manufactured from custom drop-forged quality steel and heat-treated for strength and durability. Grips are individually inspected and rigorously tested to ensure the highest quality and reliability you have come to expect from Klein Tools.



Pros know the difference™

Utility Catalog

**AMERICA
DEPENDS
on LINEMEN**

**LINEMEN
DEPEND
on Klein Tools**

**KLEIN
TOOLS®**

www.kleintools.com

Klein Tools, Inc.
450 Bond Street, Lincolnshire, IL 60069
Phone: 800.553.4676 / 847.821.5500
Fax: 800.553.4876 / 847.478.0625